



Model: 485LDRC9
**Industrial DIN Rail Mounted
 Optically Isolated RS-232 to RS-422/485
 Converter with Surge Suppression**



Features

- ✓ **High Speed Communications. Supports data rates up to 115.2 kbps.**
- ✓ **2000V 2-Way Optical Isolation.**
- ✓ **500W Surge Suppression.**
- ✓ **Industrial DIN Rail Mount.**
- ✓ **Wide Temperature Range (-40 to +80 C, -40 to +176 F)**
- ✓ **MODBUS or ASCII RTU Compatible.**

Functional Description

The 485LDRC9 is an industrial RS-232 to RS-422/485 converter. RS-232 signals interface via a terminal block or a convenient DB9 (DCE) female connector. RS-422/485 signals are connect to a terminal block. B&B's Automatic Send Data Control circuitry eliminates the requirement for software control of the RS-422/RS-485 handshake signals. Position the DIP Switches in accordance with tables one and two to change the communications mode and data rate. You can also use a pair of these converters to extend and isolate RS-232 signals. An external 10 – 30 VDC power supply (not included), is required.

Ordering Information

Model Number	Description
485LDRC9	DIN Rail Mount Converter
Accessory Items	
PS5R-A12	DIN Rail Mount Power Supply (12 VDC @7.5 W)
PS5R-A24	DIN Rail Mount Power Supply (24 VDC @ 75 W)
9PAMFx	DB9 Male to Female Cable. Various lengths available.
232NM9MFx	DB9 Male to Female Null Modem Cable (pins 2 and 3 crossed). Various lengths available.



International Headquarters: 707 Dayton Road PO Box 1040 Ottawa, IL 61350 USA
 815-433-5100 Fax 433-5104 www.bb-elec.com orders@bb-elec.com support@bb-elec.com

European Headquarters: Westlink Commercial Park Oranmore Co. Galway Ireland
 +353 91 792444 Fax +353 91 792445 www.bb-europe.com orders@bb-europe.com support@bb-europe.com

Operation

- Select Data rate and mode by positioning the DIP Switches in accordance with Table 1 and 2.
- Automatic Send Data Control: The first bit of data from the RS-232 side enables the transmitter and disables the receiver. After receiving the last RS-232 data bit, the timeout circuit waits one character length, then disables the transmitter and enables the receiver. Select the timeout by positioning the DIP Switches or changing the value of R-11. Refer to Table 2 for R-11 values and DIP Switch positions.
- If necessary, use termination resistance for high data rates or long cable runs by positioning Switch 5 to "on." Refer to B&B's RS-422/485 Application Note available for download at: http://www.bb-elec.com/tech_articles/rs422_485_app_note/table_of_contents.asp
- Figures one through four are examples of a DTE to DCE connection. The DB9 female connector on this converter will make the same connections using a straight through DB9F to DB9M cable. If the RS-232 device is wired for DCE, then cross pins 2 and 3. Refer to B&B's 485LDRC9 Converter FAQ for details regarding RS-232 wiring. It is available for download at: http://www.bb-elec.com/bb-elec/literature/Tech/FAQ_485LDRC9_Terminals.pdf
- Figure 5 is a mechanical drawing of the converter. It also includes information concerning DIP Switch orientation and the signals associated with the terminal board and DB9 connector.
- Figure 6 demonstrates how to use two converters to extend and isolate RS-232 signals. Detailed information is available for download at: http://www.bb-elec.com/bb-elec/literature/tech/FAQ_485LDRC9_Extending_RS232_Connections.pdf

Figure 1 – 2-Wire RS-485

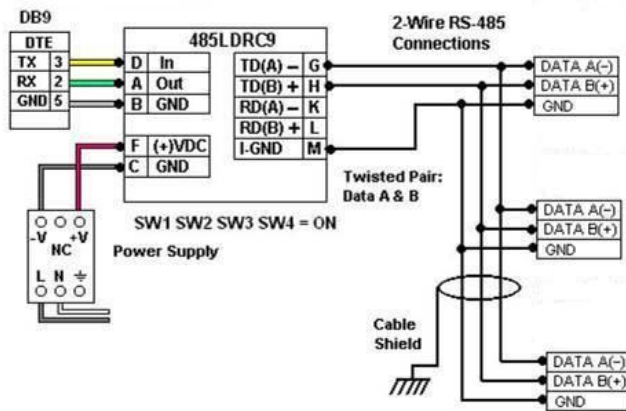

Figure 2 – 4-Wire RS-485

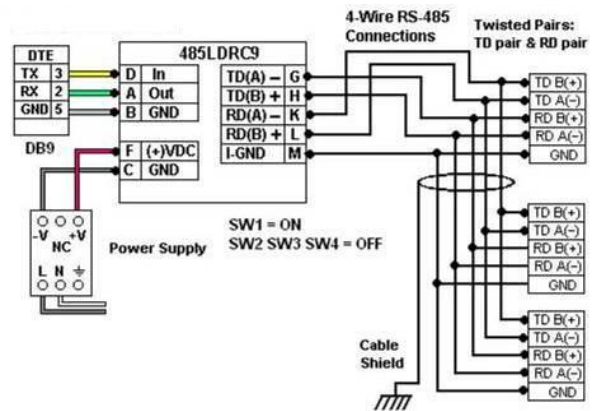

Figure 3 – RS-422

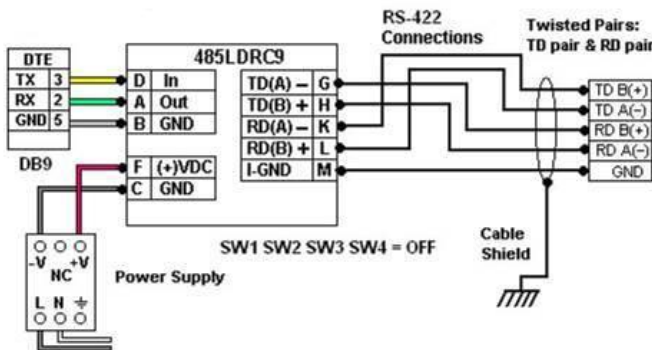

Figure 4 – 2-Wire RS-422 (No RCV)

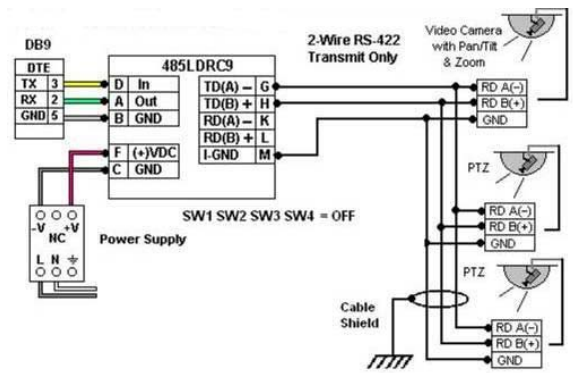
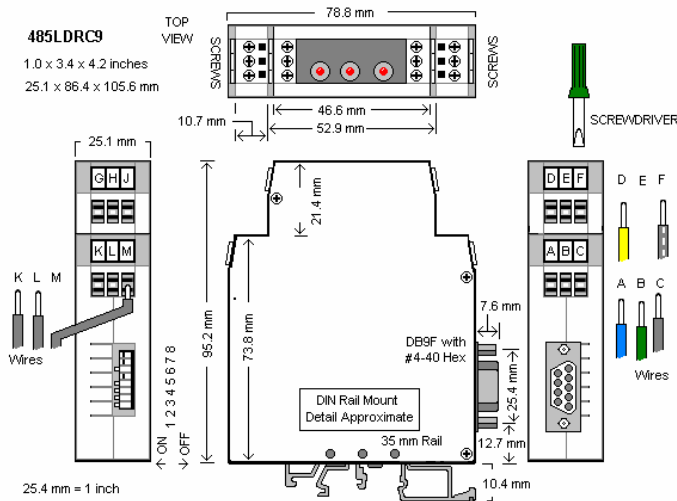

Figure 5 – Mechanical Drawing



RS-232
 TD = TB Position D / DB9 Pin 3
 RD = TB Position A / DB9 Pin 2
 Signal Ground = TB Position B / DB9 Pin 5

RS-422/485
 TD A (-) = TB Position G
 RD A (-) = TB Position K
 TD B (+) = TB Position H
 RD B (+) = TB Position L
 Isolated Ground = TB Position M

Power
 +10 to 30 VDC = TB Position F
 Power Ground = TB Position C

Figure 6 – Extend and Isolate RS-232

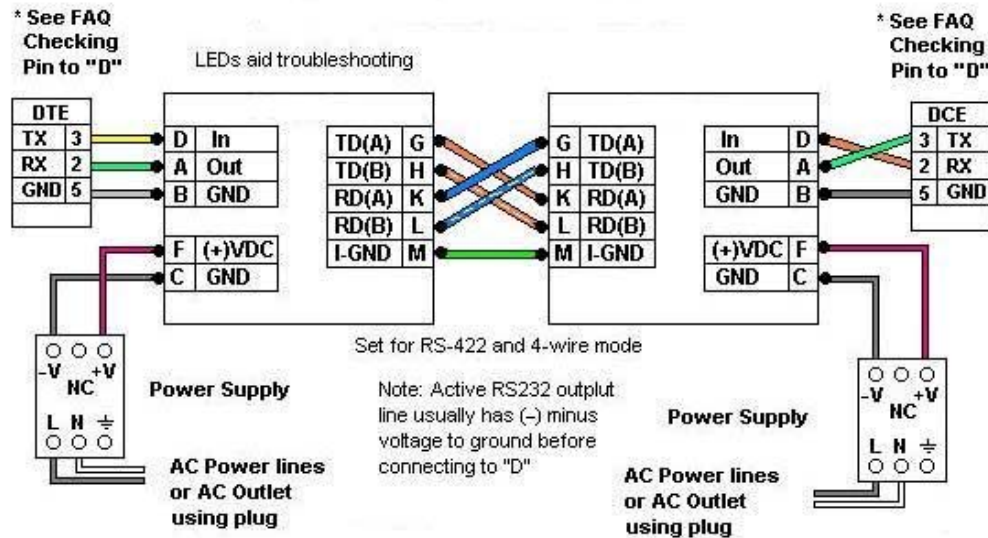

Table 1 – Communications Mode Selection

	Switch 1 TX Enable	Switch 2 RX Enable	Switch 3 2/4 Wire	Switch 4 2/4 Wire
RS-485 2-Wire (Half Duplex)	ON	ON	ON	ON
RS-485 4-Wire (Full Duplex)	ON	OFF	OFF	OFF
RS-422 (Full Duplex)	OFF	OFF	OFF	OFF

Table 2 – Data Rate Selection

	Switch 6	Switch 7	Switch 8	R11	Timeout (ms)
1200	OFF	OFF	OFF	820 KΩ	8.33
2400	OFF	OFF	ON	NOT USED	4.16
4800	OFF	ON	OFF	NOT USED	2.08
9600	ON	OFF	OFF	NOT USED	1.04
19200	ON	ON	ON	NOT USED	.580
38400	OFF	OFF	OFF	27 KΩ	.260
57600	OFF	OFF	OFF	16 KΩ	.176
115200	OFF	OFF	OFF	8.2 KΩ	.0868

Specifications

Input Power Requirement	+10 – 30 VDC.
Isolation	2000 VAC Optical Isolation of data signals and ground.
Surge Suppression	7.5 V, bi-directional avalanche breakdown device, 500W peak power dissipation. Clamping time <1 picosecond (theoretical).
Signal Connectors	Terminal Block for RS-232/422/485. Additional RS-232 connection via DB9 (female).
Data Rate	1200 to 115200 bps (2400 to 19200 DIP Switch Selectable).
Operating Temperature	-40 to +80 C (-40 to +176 F).
Operating Humidity	0 to 95% non-condensing.
LED Indicators	Receive Data, Transmit Data, and Power.
Dimensions	25x86x107 mm (1x3.4x4.2 in)
DIN Mount	35 mm DIN
Approvals	CE, RoHS

DECLARATION OF CONFORMITY

Manufacturer's Name: B&B Electronics Manufacturing Company
 Manufacturer's Address: P.O. Box 1040
 707 Dayton Road
 Ottawa, IL 61350 USA
 Model Numbers: 485OPDRI
 Description: Industrial RS-422/485 Isolator/Repeater
 Type: Light industrial ITE equipment
 Application of Council Directive: 89/336/EEC
 Standards: EN 55022
 EN 61000-6-1
 EN 61000 (-4-2, -4-3, -4-4, -4-5, -4-6, -4-8, -4-11)



Michael J. Fahrion, Director of Engineering



International Headquarters: 707 Dayton Road PO Box 1040 Ottawa, IL 61350 USA
 815-433-5100 Fax 433-5104 www.bb-elec.com orders@bb-elec.com support@bb-elec.com

European Headquarters: Westlink Commercial Park Oranmore Co. Galway Ireland
 +353 91 792444 Fax +353 91 792445 www.bb-europe.com orders@bb-europe.com support@bb-europe.com