



## Model 232SPHI4 High-Speed Port-Powered RS-232 Optical Isolator

The Model 232SPHI4 isolates and protects RS-232 equipment from lightning surges, accidental high voltage shorts, and ground loops. RS-232 data signals at up to 115.2K bps as well as the RTS and CTS handshake lines are supported. The 232SPHI4 provides 4000 Volts of isolation between sides, and maintains creepage and air clearances required for double or reinforced insulation by IEC 601-1.

The two sides of the isolator are powered independently to maintain isolation. Both sides are capable of deriving power from the RS-232 data and handshake lines, eliminating external powering requirements in nearly all systems. If the isolator is to be used with low power ports or when no handshake lines are available, external power can also be supplied to either side. This versatile powering configuration minimizes the number of supplies required by the system. DTE device connections are made through a DB-25 female. DCE device connections are made through a DB-25 male. Signal paths through the isolator are shown in Figure 1.

**Figure 1: 232SPHI4 Block Diagram**

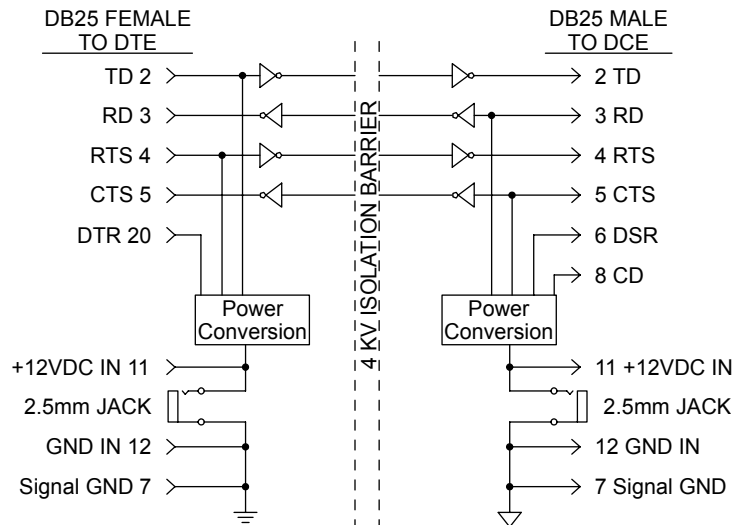

When connecting the 232SPHI4 it is recommended that all device output signals be connected. The 232SPHI4 derives power from these signals, even if they are not used by your system.

On a DTE device, with a DB-25 pin connector, the following lines are outputs:

- TD(2)
- RTS(4)
- DTE READY(DTR) (20)

On a DCE device, with a DB-25 pin connector, the following lines are outputs:

- RD(3)
- CTS(5)
- DCE READY(DSR) (6)
- RLSD(CD) (8)

On a DB-9 pin IBM compatible computer with a standard serial port, a standard 9 to 25 pin adapter can be used for connecting to the 232SPHI4. The outputs on a 9-pin DTE are:

- TD(3)
- RTS(7)
- DTE READY(DTR) (4)

Typical DTE devices include PCs, terminals, and printers. Typical DCE devices include modems and multiplexers. Most DTE ports are male and most DCE ports are female. If the 232SPHI4 is inserted into a working system, it will only pass signals if inserted correctly. If the devices communicate with each other without the 232SPHI4 in the line, but not when it is installed, simply reverse the isolator.

If your port meets the low voltage requirements of RS-562, you may need to externally power the isolator. An RS-562 port will only produce about 3.7 volts, which is not adequate to power the isolator. This type of port is generally found only on palmtop or very low power laptop computers.

Each side of the 232SPHI4 can be powered independently. To externally power either side of the isolator, connect to a +12 V power supply. Power can be connected through either the power jacks or through the DB25 connectors on pins 11 (+) and 12 (-). Care should be taken when choosing the power supply if the full 4 KV isolation is required for your system. Many inexpensive supplies, including the unregulated supplies sold by B&B Electronics, only provide 1500V AC isolation between the primary and secondary windings. If both sides of the isolator require external power, two separate isolated supplies are required.

**NOTE: When using an external supply, the supply should be connected only to specifically labeled power inputs. Connecting an external power supply to the handshake lines may damage the unit.**

**Specifications:**

Transmission Mode:	Asynchronous, half or full duplex, point-to-point
Interface:	RS-232
Signals Supported:	Transmit Data, Receive Data, Request to Send, Clear to Send
Data Rates:	0 to 115.2 K bps
Connectors:	To DTE, DB-25 female; To DCE, DB-25 male
Power Requirements:	Port-powered from RS-232 data and handshake lines
Optional External Power:	+10 to +16 VDC @ 40 mA max
External Power Connections:	2.5mm power jacks (tip positive) or DB25 connectors pins 11 (+) and 12 (-)
Isolation:	4000 Volts RMS isolation for 1 minute (May be limited by external supply)
Dimensions:	4.1"L x 2.3"W x 0.95" H (10.4 x 5.8 x 2.4 cm)

Minimum Air Clearance between DTE & DCE Sides:	0.197" (5mm)
Minimum Creepage Distance between DTE & DCE Sides:	0.315" (8mm)

DECLARATION OF CONFORMITY	
Manufacturer's Name:	B&B Electronics Manufacturing Company
Manufacturer's Address:	P.O. Box 1040 707 Dayton Road Ottawa, IL 61350 USA
Model Numbers:	232SPHI4
Description:	4-Channel RS-232 Optical Isolator
Type:	Light industrial ITE equipment
Application of Council Directive:	89/336/EEC
Standards:	EN 55022 EN 61000-6-1 EN 61000 (-4-2, -4-3, -4-4, -4-5, -4-6, -4-8, -4-11)
 William H. Franklin III, Director of Engineering	
