

# PSI-MOS-RS485W2/FO 1300 E Serial to Fiber Converter

 [perle.com/products/serial-fiber-converters/psi-mos-rs485w2-fo1300e-rs485-to-fiber.shtml](http://perle.com/products/serial-fiber-converters/psi-mos-rs485w2-fo1300e-rs485-to-fiber.shtml)

## Connect 2-wire RS485 devices to fiber optic cable

- Extend serial data up to 28 miles
- Immune to EMI, RFI and transient surges
- Point-to-point or star configuration
- SC type fiber connectors
- Terminal Block for 2-wire RS485 Connections

The PSI-MOS-RS485W2/FO 1300 E can be used to convert RS485 2-wire devices to fiber optics. By transmitting serial data over optical fiber, these serial media converters provide an economical path to extend the reach of RS485 devices. All protocols with 10/11-bit UART data format and NRZ data coding are supported. This includes popular protocols such as:

- Modbus ASCII / MODBUS RTU
- SUCONET K
- S-BUS
- DH-485, and more...



## Long Distance Serial Data Transmission over Fiber

RS485 Serial transmission is commonly limited to 100 kbps over a distance of only 1200 meters (4000 feet). Using the FO 1300 E Serial to Fiber Converter you can extend your serial data transmission up to 27km (16.7 miles) over multimode fiber or 45km (28 miles) over single mode fiber. The result is that any two pieces of asynchronous serial equipment, located miles apart, can communicate at half duplex over fiber optic cable at rates up to 500 kbps.

## EMI, RFI and Transient Surge Immunity

Another advantage of the FO 1300 E fiber optic transmission system is the electrically isolated connection of devices. Electromagnetic interference (EMI) is a common phenomenon in typical environments like industrial plants, warehouses and factory floors. This interference can cause corruption of data over RS485 or copper-based Ethernet links. Data transmitted over fiber optic cable however is completely immune to this type of noise, thus preventing the negative effects of voltage equalization currents and electromagnetic interference on the data cables. A Serial to Fiber Media Converter therefore enables you to inter-connect your serial devices over fiber ensuring optimal data transmission, increased availability of the system, and improved network design flexibility for point-to-point connections and star structures.

## Flexible Fiber Optic Connections

The FO 1300 E operates at 1300 nm wavelength, using a separate LED emitter and photo-detector on SC type connectors. Almost any multimode or single mode glass fiber size can be used.

## Power Budget Considerations

Calculating the power budget is critically important with planning the fiber optic link. The optical power budget is the

amount of light required to transmit data successfully over distance through a fiber-optic connection. The amount of light energy available within the setup will dictate the length of the fiber optic cable run between serial media converters within the network. Optical power budgets are critical to help businesses avoid signal distortion. [To learn how to calculate optical power budget read our technical note.](#) Transmit and receive dBm can be found in the Hardware specifications.

## Transmit each serial signal out over 10 fiber optic lines

Up to ten (10) Serial to Fiber Converters can be grouped together using the TBUS DIN Rail bus system for voltage and data. This allows the serial converter to operate as a star coupler, taking the serial data input signal and distributing it to all Fiber optic output ports.

## High Quality Features and Support

The FO 1300 E are also equipped with comprehensive diagnostic functions to increase system availability, simplify start-up and permanently monitor the optical transmission quality. The integrated optical diagnostics allow permanent monitoring of the FO paths during installation and operation. The floating switch contact is activated when the signal level on the fiber optic paths reaches a critical level. This early alarm generation enables critical system states to be detected before they result in failure. These cost and time saving features, along with free worldwide technical support, make the FO 1300 E serial to fiber converter the smart choice for IT professionals.

- Supply voltage and data signals routed through via DIN rail connectors
- Connections can be plugged in using a COMBICON screw terminal block
- Automatic data rate detection or fixed data rate setting via DIP switches
- Redundant power supply possible by means of optional system power supply unit
- High-quality electrical isolation between all interfaces (RS-485, fiber optic ports, power supply, DIN rail connector)
- Approved for use in zone 2
- Integrated optical diagnostics for continuous monitoring of fiber optic paths
- Floating switch contact for leading alarm generation in relation to critical fiber optic paths
- Suitable for data rates up to 500 kbps



**RS-232**



## PSI-MOS-RS485/FO 1300 E Technical Specifications

### Ambient conditions

Ambient temperature (operation)	-20 °C ... 60 °C
Ambient temperature (storage/transport)	-40 °C ... 85 °C
Permissible humidity (operation)	30 % ... 95 % (non-condensing)
Altitude	5000 m (For restrictions see manufacturer's declaration)
Degree of protection	IP20
Noise immunity	EN 61000-6-2:2005

### Standards and Regulations

Electromagnetic compatibility	Conformance with EMC directive 89/336/EC
Type of test	Vibration resistance in acc. with EN 60068-2-6/IEC 60068-2-6
Test result	5g, 10-150 Hz, 2.5 h, in XYZ direction
Type of test	Shock in acc. with EN 60068-2-27/IEC 60068-2-27
Test result	15g, 11 ms period, half-sine shock pulse
Shock	15g in all directions in acc. with IEC 60068-2-27
Noise emission	EN 55011
Noise immunity	EN 61000-6-2:2005
Free from substances that could impair the application of coating	according to P-VW 3.10.7 57 65 0 VW-AUDI-Seat central standard
Connection in acc. with standard	CUL
Standards/regulations	EN 61000-4-2 EN 61000-4-3 EN 61000-4-4 EN 61000-4-5 EN 61000-4-6
Vibration (operation)	In acc. with IEC 60068-2-6: 5g, 150 Hz

Conformance	CE-compliant
ATEX	II 3 G Ex nA nC IIC T4 Gc X
UL, USA/Canada	508 listed 508 recognized
<b>Optical interface FO</b>	
Number of FO ports	1
Wavelength	1300 nm
Transmission length incl. 3 dB system reserve	25 km (With F-G 50/125 0.7 dB/km at 1300 nm) 22 km (with F-G 62.5/125 0.8 dB/km at 1300 nm) 45 km (With F-E 9/125 0,4 dB/km at 1300 nm)
Transmission medium	Multi-mode fiberglass Single-mode fiberglass
Transmission protocol	Protocol-transparent to the RS-485 interface
Connection method	SC duplex
<b>General</b>	
Bit distortion, input	± 35 % (permitted)
Bit distortion, output	< 6.25 %
Electrical isolation	VCC // RS-485
Test voltage data interface/power supply	1.5 kVrms (50 Hz, 1 min.)
Electromagnetic compatibility	Conformance with EMC directive 89/336/EC
Noise emission	EN 55011
Net weight	225.3 g
Housing material	PA 6.6-FR
Color	green
MTBF	484 Years (Telcordia standard, 25°C temperature, 21% operating cycle (5 days a week, 8 hours a day)) 102 Years (Telcordia standard, 40°C temperature, 34.25% operating cycle (5 days a week, 12 hours a day))
Conformance	CE-compliant

ATEX	II 3 G Ex nA nC IIC T4 Gc X (Please follow the special installation instructions in the documentation!)
UL, USA/Canada	508 listed 508 recognized
<b>Digital outputs</b>	
Output name	Relay output
Output description	Alarm output
Number of outputs	1
Maximum switching voltage	60 V DC 42 V AC
Limiting continuous current	1:00 AM
<b>Power supply</b>	
Nominal supply voltage	24 V DC (With UL approval)
Supply voltage range	18 V DC ... 32 V DC
Max. current consumption	90 mA
Typical current consumption	55 mA (24 V DC)
Connection method	COMBICON plug-in screw terminal block
Typical current consumption	170 mA (According to UL Listed, 24 V DC) 110 mA (According to UL Recognized, 24 V DC)
<b>Serial interface</b>	
Interface 1	RS-485 interface, 2-wire
Operating mode	Semi-duplex
Connection method	Pluggable screw connection
File format/coding	UART (11/10 bit switchable; NRZ), slip-tolerant
Data direction switching	Automatic control
Transmission medium	Copper
Transmission length	≤ 1200 m (depending on the data rate, with shielded, twisted data cable)

Termination resistor	390 Ω 220 Ω 390 Ω (Can be connected)
Conductor cross section solid min.	0.2 mm <sup>2</sup>
Conductor cross section solid max.	2.5 mm <sup>2</sup>
Conductor cross section flexible min.	0.2 mm <sup>2</sup>
Conductor cross section flexible max.	2.5 mm <sup>2</sup>
Conductor cross section AWG min.	24
Conductor cross section AWG max.	14
Serial transmission speed	4.8/ 9.6/ 19.2/ 38.4/ 57.6/ 75/ 93.75/ 115.2/ 136/ 187.5/ 375/ 500 kbps

### Dimensions

Width	35 mm
Height	99 mm
Depth	105 mm

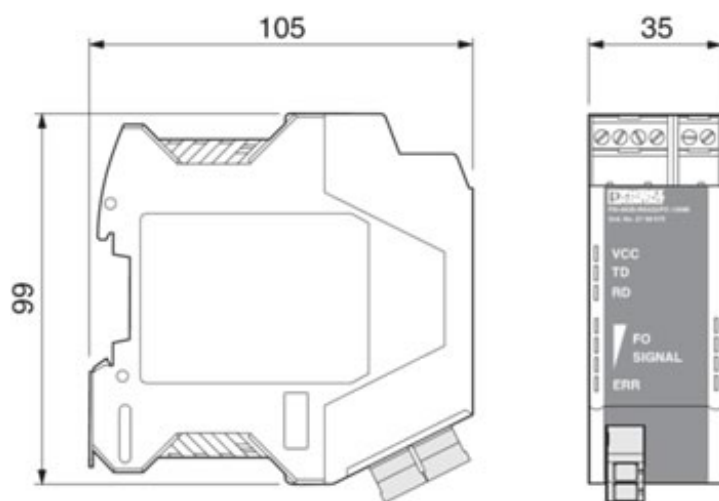

### Environmental Product Compliance

China RoHS	Environmentally Friendly Use Period = 50
Reach and RoHS Compliant	<a href="#">Reach and RoHS Compliant</a>

### Approvals

---

cUL Listed  
cULus Listed  
UL Listed  
ATEX  
EAC  
DNV  
cUL Recognized  
cULus Recognized  
UL Recognized

---

**Commercial data**

---

Packing unit	1
Weight per piece	230.1 g
Country of origin	Germany
Warranty	1 Year

---

**Classifications**

---

eCl@ss 4.0	27230207
eCl@ss 4.1	27230207
eCl@ss 5.0	27230207
eCl@ss 5.1	27230207
eCl@ss 6.0	27230207
eCl@ss 7.0	27230207
eCl@ss 8.0	19179290
eCl@ss 9.0	19179290
ETIM 2.0	EC001423
ETIM 3.0	EC001423
ETIM 4.0	EC001423
ETIM 5.0	EC000310
ETIM 6.0	EC000310
UNSPSC 6.01	30211506
UNSPSC 7.0901	39121008

---

---

UNSPSC 11	39121008
UNSPSC 12.01	39121008
UNSPSC 13.2	43222604

---

### PSI-MOS-RS485/FO 1300 E Serial to Fiber Media Converter Applications

---

- near heavy electrical equipment
  - in environments with electrical (EMI) or radio (RFI) interference
  - in environments with transient surges
  - in industrial plants, warehouses and factory floors
  - enabling asynchronous serial equipment to communicate at half duplex, with rates up to 500 kbps, over optical fiber
- 

#### Point-to-point connections between serial devices over fiber

---

You can use two PSI-MOS-RS485W2/FO 1300 E Serial to Fiber Converters to easily convert a data link from copper cable to fiber optics.

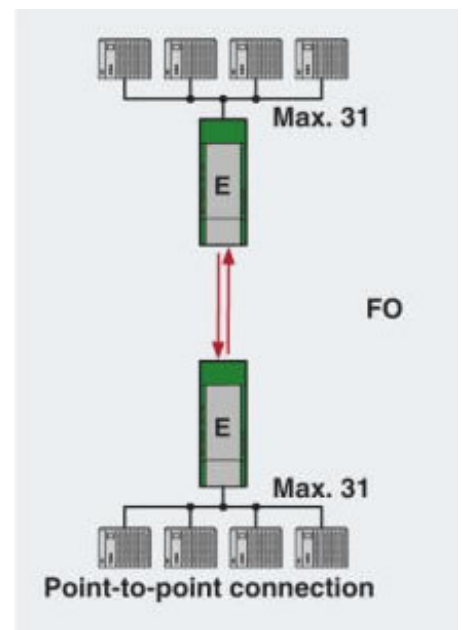

---

#### Linear Networks

---



The PSI-MOS-RS485W2/FO 1300 E device can be used to network several RS-485 devices to form a linear structure. Devices are used in conjunction with DIN rail connectors along the line.

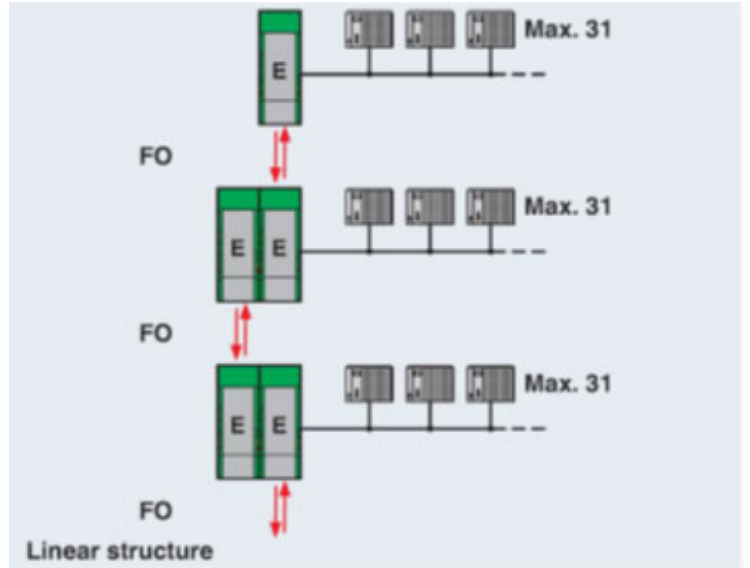

---

### Star structures

---

You can network RS-485 2-wire devices within a star structure. Depending on the number of star lines required, several PSI-MOS-RS485W2/FO 1300 E Serial to Fiber Converters are connected to TBUS DIN Rail bus systems for voltage and data. This makes up to 10 fiber optic ports available. Cross-wiring for serial data and for the supply voltage is provided automatically by the DIN rail connector.

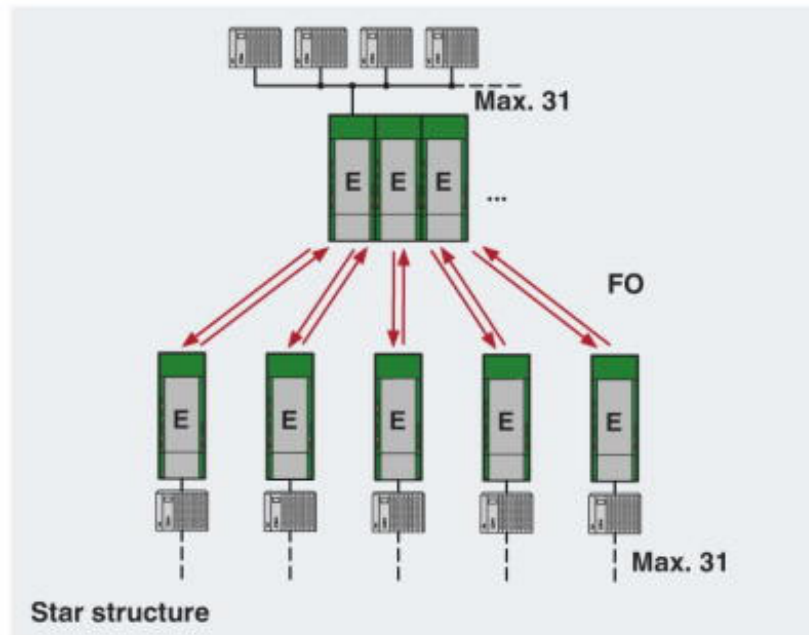

---

### Tree structures

---

Linear and star structures can be cascaded to create complex tree structures. The number of devices that can be cascaded is only limited by the timing response (timeout) of the bus system used due to the bit retiming of the PSI-MOS-RS485W2/FO 1300 E fiber optic converter.

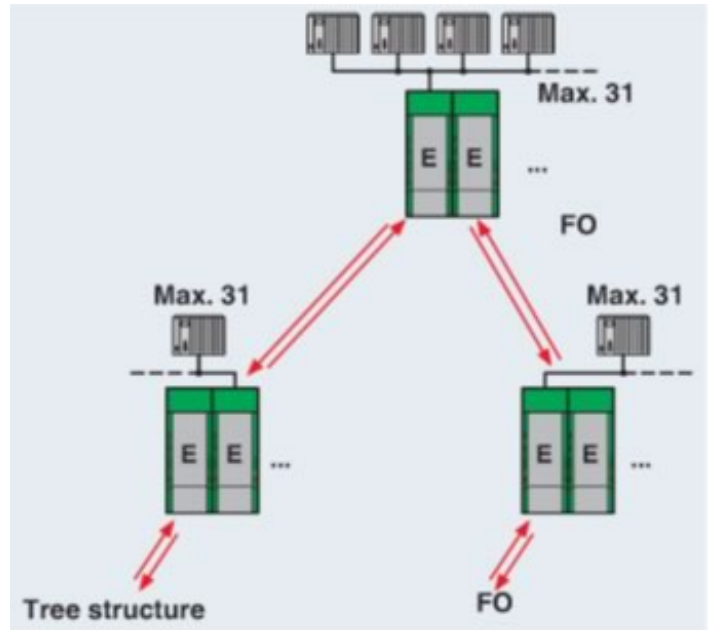

---

### Block Diagram

---

