

QUINT-PS/2AC/1DC/24DC/20 DIN Rail Power Supply

perle.com/products/industrial-power-supply/quint-high-input.shtml

DC to DC Converter for Frequency or Power Inverter

- 24V DC Output Voltage
- 20 Amps Output
- 480 Watts Output
- Dual-phase AC or DC Input
- Input Voltage Range: 360 to 575 V AC or 450 to 840 V DC

The **QUINT POWER power supply** is specifically designed for connection to high input voltages such as frequency converters. It can be simultaneously connected to the AC voltage and the DC intermediate circuit voltage of a converter. In the event of mains failure, the energy of the DC intermediate circuit continues to supply all connected 24 V loads without interruption. With all required safety certifications to support ITE (Information Technology Equipment), ruggedized packaging, extended operating temperatures, high peak load capabilities and high isolation voltages, the QUINT Industrial Power Supply is designed to meet the needs of your industrial application. The QUINT-PS/2AC/1DC/24DC/20 uses leading technologies to increase safety and reliability:

- Preventive function monitoring warns against critical operating states before errors occur.
- The static power reserve enables difficult loads to be started reliably with up to 1.25 times the nominal current (POWER BOOST).
- Fast tripping of standard circuit breakers with up to six times the nominal current for 12 ms (SFB technology).

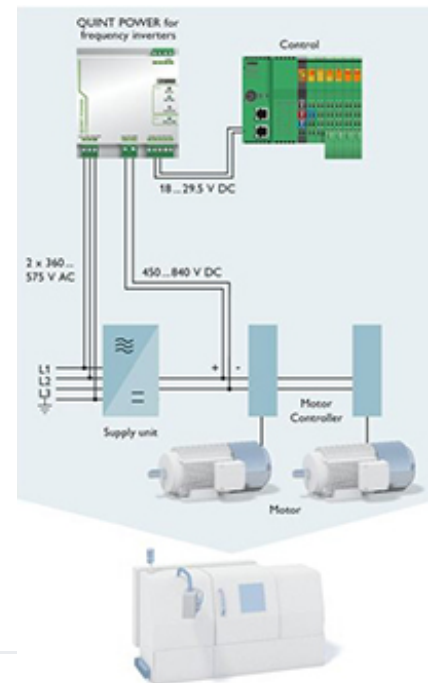

18 to 29.5 V DC Adjustable Output Voltage Range

Using the rotary potentiometer on the front face of the QUINT power supply, the output voltage can be optimally adjusted to meet specific application environment requirements. For example, you can easily adjust to compensate for a voltage drop caused by a long cable length.

POWER BOOST: reliably start difficult loads

A high degree of flexibility is required to configure, optimize and expand large systems. To optimally adapt a system or machine to your requirements, a power reserve in the power supply unit is crucial. With the QUINT Power Boost function a **static boost will continuously provide up to 125%** of the nominal current. This is useful when it is not possible to predict which loads will be switched on at the same time or high switch-on currents of capacitive loads have to be absorbed without voltage dips.

Preventive function monitoring reports critical operating states before they occur

With a QUINT Industrial Power Supply, the output voltage and output current are constantly monitored. Preventive function monitoring visualizes critical operating states and indicates them locally and remotely to the controller as follows:

- Via LED
- Via floating relay contact
- Via active switching output

Industrial operating temperature of -25°C to $+70^{\circ}\text{C}$

Equipment found in traffic management, oil and gas pipelines, weather tracking, industrial and outdoor applications must function in temperatures that cannot be supported by a commercial power supplies. With an operating temperature of -25°C to $+70^{\circ}\text{C}$ the QUINT Industrial Power Supply is ideal for use with equipment subjected to harsh environments and severe temperatures.

High efficiency and low no load power consumption

Compared with other products on the market, the QUINT Industrial Power Supply provides excellent energy savings. With a very low no load power consumption and high efficiency at nominal load, just a small amount of electrical energy is converted into undesired heat energy making these very ECO friendly power supplies.

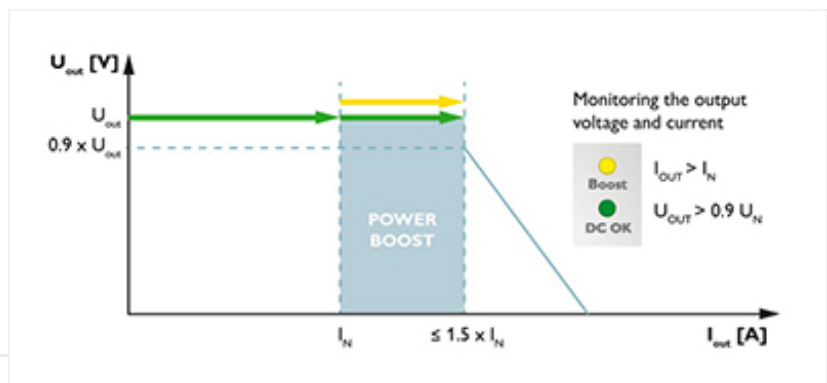
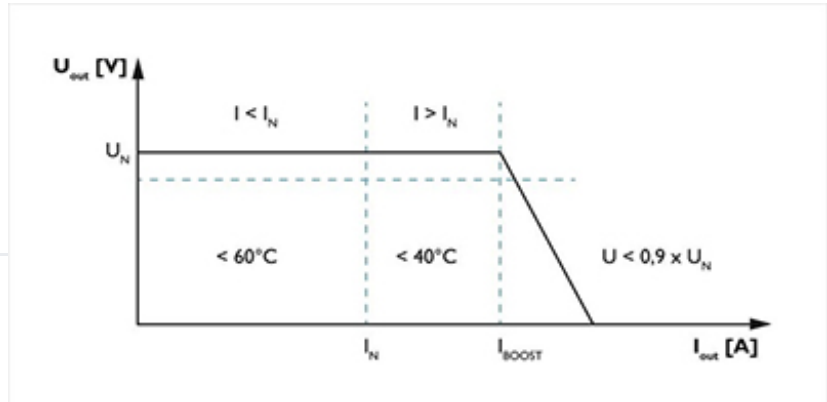

SFB (Selective Fuse Breaking) Technology

SFB Technology can be used to quickly and reliably trip miniature circuit breakers and fuses connected on the secondary side. In the event of a short circuit on the secondary side, the QUINT supplies up to 6 times the nominal current for 12 ms. Faulty current paths are switched off selectively, the fault is located, and important system parts remain in operation. Loads that are connected in parallel are still supplied with energy ensuring continued operation of these system parts.

- Tripping circuit breakers: The circuit breaker is typically tripped by the high SFB current within 3 to 5 ms. As a result, any voltage dips for loads connected in parallel are avoided.
- Tripping a fuse: Fuses are tripped by melting the predetermined breaking point inside the fuse capsule. The tripping characteristic of the fuse is described by the melting integral (I^2t). A high current is crucial in order to achieve a very short tripping time.

Ideal application environments for a QUINT DIN Rail Power Supply

- Machine building
- Automated production process
- Industrial control, automation, assembly, and test equipment
- Building control, security and surveillance, and climate control systems.
- Power countless industrial automation devices such as sensors, controllers and valves

Other reasons to choose a QUINT Industrial DC to DC Converter

- Compact buffer solution
- Voltage Isolation input/output: 1.5 kV AC
- Protections: Short-circuit, Overload, Over voltage, Over-temperature

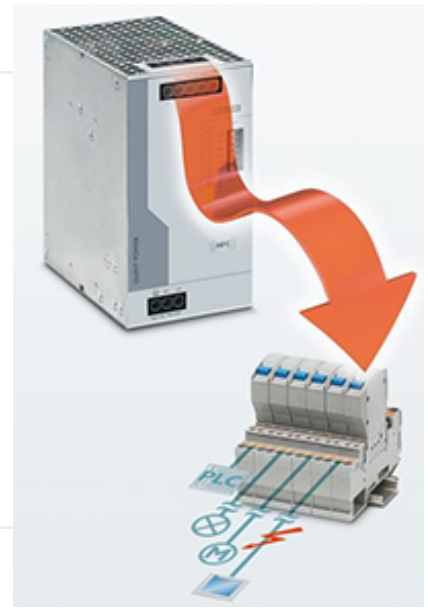

Environmental Product Compliance

REACH SVHC	Lead 7439-92-1
General	
Net weight	2 kg
Efficiency	> 92 % (600 V DC)
	> 90.5 % (400 V AC)
Insulation voltage input/output	1.5 kV AC (type test)
	2 kV AC (routine test)
Insulation voltage input / PE	4 kV AC (type test)
	1.5 kV AC (routine test)
Insulation voltage output / PE	500 V DC (routine test)
Protection class	I
Degree of protection	IP20
MTBF (IEC 61709, SN 29500)	
	> 860000 h (40 °C)
Mounting position	horizontal DIN rail NS 35, EN 60715

Assembly instructions	alignable: $P_N \geq 50\%$, 5 mm horizontally, 15 mm next to active components, 50 mm vertically alignable: $P_N < 50\%$, 0 mm horizontally, 40 mm vertically top, 20 mm vertically bottom
-----------------------	---

Standards and Regulations

Electromagnetic compatibility	Conformance with EMC Directive 2014/30/EU
Connection in acc. with standard	CUL
Standard - Safety of transformers	EN 61558-2-17
Standard - Electrical safety	EN 60950-1/VDE 0805 (SELV) EN 61558-2-17
Standard – Electronic equipment for use in electrical power installations and their assembly into electrical power installations	EN 50178/VDE 0160 (PELV)
Standard - Safe isolation	DIN VDE 0100-410
UL approvals	UL/C-UL listed UL 508 UL/C-UL Recognized UL 60950-1
Shock	18 ms, 30g, in each space direction (according to IEC 60068-2-27)
Vibration (operation)	< 15 Hz, amplitude ± 2.5 mm (according to IEC 60068-2-6) 15 Hz ... 150 Hz, 2.3g, 90 min.
Rail applications	EN 50121-4

Connection data, input

Connection method	Screw connection
Conductor cross section solid min.	0.2 mm ²
Conductor cross section solid max.	6 mm ²
Conductor cross section flexible min.	0.2 mm ²
Conductor cross section flexible max.	4 mm ²
Conductor cross section AWG min.	24
Conductor cross section AWG max.	10
Stripping length	8 mm
Screw thread	M3

Output data

Nominal output voltage	24 V DC ± 1 %
------------------------	-------------------

Setting range of the output voltage (U_{Set})	18 V DC ... 29.5 V DC ($U_{IN} \geq 360$ V AC / 480 V DC)
	18 V DC ... 26 V DC (< 480 V DC)
Nominal output current (I_N)	20 A (-25 °C ... 60 °C)
POWER BOOST (I_{Boost})	26 A (-25°C ... 40°C permanent, $U_{OUT} = 24$ V DC)
Selective Fuse Breaking (I_{SFB})	120 A (20 ms)
Derating	60 °C ... 70 °C (2.5%/K)
Connection in parallel	Yes, for redundancy and increased capacity
Connection in series	yes
Feedback resistance	< 35 V DC
Protection against surge voltage on the output	Yes, limited to approx. 35 V DC
Max. capacitive load	Unlimited
Active current limitation	Approx. 27 A
Control deviation	< 1 % (change in load, static 10 % ... 90 %)
	< 2 % (change in load, dynamic 10 % ... 90 %)
	< 0.1 % (change in input voltage ± 10 %)
Residual ripple	< 50 mV _{PP} (with nominal values)
Output power	480 W
Peak switching voltages nominal load	< 50 mV _{PP} (20 MHz)
Maximum power dissipation in no-load condition	11 W
Power loss nominal load max.	51 W

Connection data for signaling

Conductor cross section solid min.	0.2 mm ²
Conductor cross section solid max.	6 mm ²
Conductor cross section flexible min.	0.2 mm ²
Conductor cross section flexible max.	4 mm ²
Conductor cross section AWG min.	24
Conductor cross section AWG max.	10
Screw thread	M3

Dimensions

Width	120 mm
Height	130 mm
Depth	125 mm
Weight per piece	2000.0 GRM

Note

Utilization restriction	EMC: class A product, see manufacturer's declaration in the download area
-------------------------	---

Input data

Nominal input voltage range	2x 400 V AC ... 500 V AC
	600 V DC
Input voltage range	2x 360 V AC ... 575 V AC
	450 V DC ... 840 V DC
AC frequency range	45 Hz ... 65 Hz
Frequency range DC	0 Hz
Current consumption	2.5 A (400 V AC)
	2.1 A (500 V AC)
Nominal power consumption	888 VA
Inrush surge current	< 85 A (typical)
Mains buffering	typ. 20 ms (400 V AC)
Input fuse	3.15 A (slow-blow, internal)
Choice of suitable circuit breakers	10 A ... 16 A (Characteristic B, C)
Type of protection	Transient surge protection
Protective circuit/component	Varistor

Connection data, output

Connection method	Screw connection
Conductor cross section solid min.	0.2 mm ²
Conductor cross section solid max.	6 mm ²
Conductor cross section flexible min.	0.2 mm ²
Conductor cross section flexible max.	4 mm ²
Conductor cross section AWG min.	12
Conductor cross section AWG max.	10

Stripping length	8 mm
Screw thread	M3

Ambient conditions

Degree of protection	IP20
Ambient temperature (operation)	-25 °C ... 70 °C (> 60 °C Derating: 2.5 %/K)
Ambient temperature (storage/transport)	-40 °C ... 85 °C
Max. permissible relative humidity (operation)	≤ 95 % (at 25 °C, non-condensing)
Climatic class	3K3 (in acc. with EN 60721)
Degree of pollution	2
Installation height	≤ 2000 m

Approvals

- cULus Listed
- cULus Recognized
- EAC
- UL Recognized
- cUL Recognized
- cUL Listed
- UL Listed

Block diagram

