

CM-100MM Managed Fast Ethernet

perle.com/products/fast-ethernet-fiber-managed-converter-module.shtml

100Base-FX to 100Base-X Fiber Mode Conversion

- 100Base-FX to 100Base-X Fiber to Fiber Media Converter Module
- Multimode to multimode or multimode to single mode
- Extend multimode fiber to 120km (or more through chaining)
- Choice in SC, LC and ST fiber connector models
- Signal regeneration prevents signal degradation
- Advanced Features: Link Pass-Through, Far-End Fault, loopback for each fiber connection
- High density applications with Perle Media Converter Chassis
- Manage via SNMP, CLI - Telnet/SSH, Internet browser, or PerleVIEW Centralized Management Package with an MCR-MGT Media Converter Management Module



Installed in a high density Perle Media Converter Chassis, Perle's feature rich **CM-100MM Fast Ethernet Fiber to Fiber** Managed Media Converter Module enables transparent fiber extension of 100Base-FX multimode fiber to 100Base-FX multimode or 100Base-LX/EX/ZX/BX single mode fiber.

Perle's advanced features make the end to end fiber link completely transparent. This allows for more efficient troubleshooting and less on-site maintenance. When used with a Media Converter Management Module in the chassis, configuration and monitoring of the fiber ports can be performed. In addition, a lifetime warranty and free worldwide technical support make **Perle's CM-100MM Fast Ethernet Fiber to Fiber Managed Media Converter Modules** the smart choice for IT professionals.

For those environments requiring a medium to large-scale deployment of media converters, a centralized platform that simplifies the configuration, administration, monitoring, and troubleshooting of this gear is recommended. PerleVIEW Device Management software is a multi-user, Windows server-based application that delivers this level of Enterprise-grade solution.

Whether you need to extend **multimode to multimode** or **multimode to single mode**, Perle has an extensive range of CM-100MM Fast Ethernet Fiber to Fiber Managed Media Converter Modules to meet your fiber conversion requirement.

CM-100MM Fiber to Fiber Features: 100Base-FX to 100Base-X

Configuration Mode selection	Select whether the module is to use the on-board DIP switches or enable the management module in the chassis to manage
------------------------------	--

Module Information	<ul style="list-style-type: none"> • Chassis Slot number that the module is in • Media converter model and serial • User configurable module name • User configurable fiber port name • Hardware revision number • Firmware version number
--------------------	--

Module DIP switch settings	View hardware DIP switch settings
----------------------------	-----------------------------------

Port Control	Enable or disable individual fiber ports on the module
--------------	--

Fiber Port Status	<ul style="list-style-type: none"> • Port Enabled (Yes/No) • Connector type (SC, LC, ST) • Link Status (Up/Down) • Far End Fault (OK, Failed) • Fiber Loopback mode (On/Off)
-------------------	---

Module Control	<ul style="list-style-type: none"> • Reset card • Reset to factory default • Phy specific commands such write/read config, read dip switches • Update firmware • Fiber Loopback mode. (On/Off) • Upload/download configuration
----------------	--

Backup and Restore	Provides fast and easy module replacement. Management module will always save a copy of the media converter configuration and will restore this configuration automatically to the media module when it is detected in the slot.
--------------------	--

<u>Link Pass-Through</u>	<p>When enabled, the state of the receiver on one 100Base-X interface is reflected on the other 100Base-X fiber transmitter.</p> <p>If disabled, the 100Base-X fiber interfaces operate independently. Far-End Fault indication on the 100Base-FX fiber interface has no effect on the other interface.</p> <p>Using Link Pass-Through with Far-End Fault minimizes data loss when a fault occurs. If a fault occurs, the end devices have the indication of a failure available to making trouble shooting easier.</p>
--------------------------	---

Far-End Fault (FEF)	When enabled, the media converter transmits the Far-End Fault Indication over the fiber connection whenever a receive failure is detected. The media converter continuously monitors the fiber connection and clears the Far-End Fault Indication condition when a valid signal is received.
---------------------	--

When disabled, Far-End Fault Indications are not transmitted regardless of the condition of the receive signal on the 100Base-X fiber connection.

The action the media converter takes on receiving a Far-End Fault Indication is dependent on the Link Pass Through switch setting.

Pause (IEEE 802.3xy)	Pause signaling is an IEEE feature that temporarily suspends data transmission between two devices in the event that one of the devices becomes overwhelmed. The media converter is transparent to Pause frames.
----------------------	--

Signal Regeneration	Signal Regeneration maintains signal integrity and allows for maximum fiber to fiber connections without degradation.
---------------------	---

Cascading	Media Converters can be cascaded. Two or more Media Converters can be chained in a link to achieve even greater distances.
-----------	--

VLAN	The Media Converter is transparent to VLAN tagged packets.
------	--

Remote Loopback	The Media Converter can perform a loopback on each 100Base-X fiber interface.
-----------------	---

Indicators

Power / TST	This green LED is turned on when power is applied to the media converter. Otherwise it is off. The LED will blink slowly when in Loopback test mode.
-------------	--

Fiber link 1 / Receive activity (LK1)	This green LED is operational only when power is applied. The LED is on when the 100Base-X link is on and flashes with a 50% duty cycle when data is received.
---------------------------------------	--

Fiber link 2 on / Receive activity (LK2)	This green LED is operational only when power is applied. The LED is on when the 100Base-X link is on and flashes with a 50% duty cycle when data is received.
--	--

Switches: On-Board (If Auto/Switch strap is set to Switch)

Link Pass Through	<p><i>Enabled (Default)</i> - When the state of the receiver is changed on one of the 100Base-X interfaces it is reflected on the other 100Base-X fiber transmitter.</p> <p>When a Far-End Fault Indication is received on the fiber interface the 100Base-TX transmitter is turned off. When the Far-End Fault Indication is cleared the transmitter is turned back on.</p> <p><i>If disabled</i> , the 100Base-X fiber interfaces operate independently. Far-End Fault indication on the 100Base-FX fiber interface has no effect on the other interface.</p>
-------------------	---

Far-End Fault (FEF)	<p><i>Enabled (Default)</i> - The media converter transmits the Far-End Fault Indication over the fiber connection whenever a receive failure is detected. The media converter continuously monitors the fiber connection and clears the Far-End Fault Indication condition when a valid signal is received.</p> <p><i>When Disabled</i>, Far-End Fault Indications are not transmitted regardless of the condition of the receive signal on the 100Base-X fiber connection.</p>
---------------------	--

Remote Loopback #1	<p>The media converter can perform a loopback on the link #1 fiber interface.</p> <p><i>Disabled (Default - Up)</i></p> <p><i>Enabled</i> - The 100Base-X receiver is looped to the 100Base-X transmitter. Link #2's fiber transmitter is taken off the interface.</p>
--------------------	--

Remote Loopback #2	<p>The media converter can perform a loopback on the link #2 fiber interface.</p> <p><i>Disabled (Default - Up)</i></p> <p><i>Enabled</i> - The 100Base-X receiver is looped to the 100Base-X transmitter. Link #1's fiber transmitter is taken off the interface.</p>
--------------------	--

Configuration Mode (Strap)	<p>Auto (default) enable management module to overwrite hardware switch settings</p> <p>Switch - Use onboard DIP switches</p>
----------------------------	---

Cables

Fiber Optic Cable	<p>Multimode: 62.5 / 125, 50/125, 85/125, 100/140 micron</p> <p>Single Mode: 9/125 micron (ITU-T 625)</p>
-------------------	---

Packet Transmission Characteristics

Bit Error Rate (BER)	<10 ⁻¹²
----------------------	--------------------

Environmental Specifications

Operating Temperature	0 C to 50 C (32 F to 122 F)
Storage Temperature	minimum range of -25 C to 70 C (-13 F to 158 F)
Operating Humidity	5% to 90% non-condensing
Storage Humidity	5% to 95% non-condensing
Operating Altitude	Up to 3,048 meters (10,000 feet)
Heat Output (BTU/Hr)	11.9
Maximum Power Consumption (Watts)	3.5
MTBF (Hours)*	484,202

Mechanical - Hot Swapping Card

Edge Connector	32 pin DIN 41612 / IEC 60603-2 Type B/2 Male. First make, last break for ground and power
Card insertion and removal	Captive thumb screws enable fast insertion and removal. Can be further tighten with a screwdriver.

Product Weight

Weight	0.15 kg, 0.33 lbs
--------	-------------------

Packaging

Shipping Weight	0.33 kg, .73 lbs
Shipping Dimensions	203 x 38 x 152 mm, 8 x 1.5 x 6 inches

Regulatory Approvals

Emissions	FCC Part 15 Class A, EN55022 Class A
-----------	--------------------------------------

CISPR 22 Class A
CISPR 32:2015/EN 55032:2015 (Class A)
CISPR 24:2010/EN 55024:2010

EN61000-3-2

Immunity EN55024

Electrical Safety UL 60950-1

IEC 60950-1(ed 2); am1, am2
EN 60950-1:2006+A11:2009+A1:2010+A12:2011+A2:2013

CE

Laser Safety EN 60825-1:2007

Fiber optic transmitters on this device meet Class 1 Laser safety requirements per IEC-60825 FDA/CDRH standards and comply with 21CFR1040.10 and 21CFR1040.11.

Environmental Reach, RoHS and WEEE Compliant

Other ECCN: 5A991

HTSUS Number: 8517.62.0050

Perle Limited Lifetime Warranty

*Calculation model based on MIL-HDBK-217-FN2 @ 30 °C

High Density Fiber Distribution from Fiber Switch Equipment at Corporate Headquarters

In this enterprise campus application, up to 18 Perle CM-100MM Multimode to Single mode Media Converters are installed in the MCR1900 Media Converter Chassis. The 19th slot in the chassis is filled the MCR-MGT Management Module. All media converts in the chassis are managed by SNMP, Telnet or an internet browser interface. A remote fiber enabled Ethernet switch is connected directly to the central MCR1900 Chassis. Another S-100MM Fiber to Fiber Media Converter is connected to a remote office switch. In all cases, multimode or single-mode fiber can be used. Fiber links can be extended up to 120km using single-mode fiber.

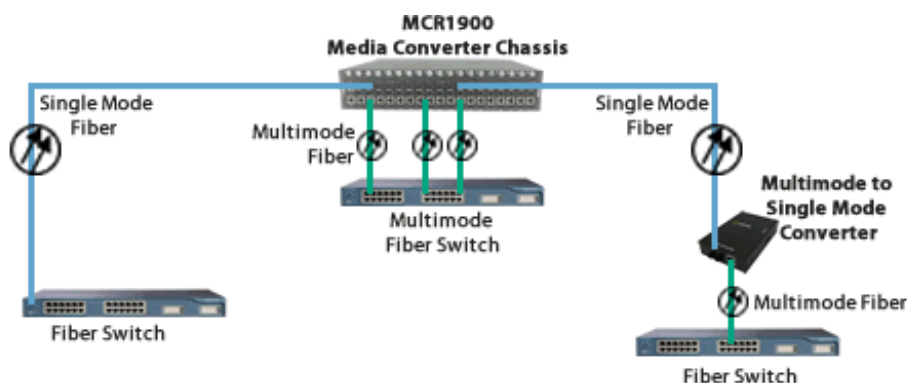

Managed Ethernet over Fiber Links

Manage your **multimode to single mode or multimode to multimode** link with an MCR200 chassis housing a media converter and management module. Ideal for use in managed networks with low density fiber applications, this Managed Media Converter is connected across a fiber link to a remote media converter. The copper or fiber link on the managed standalone unit can provide vital information and status to network management tools such as SNMP.

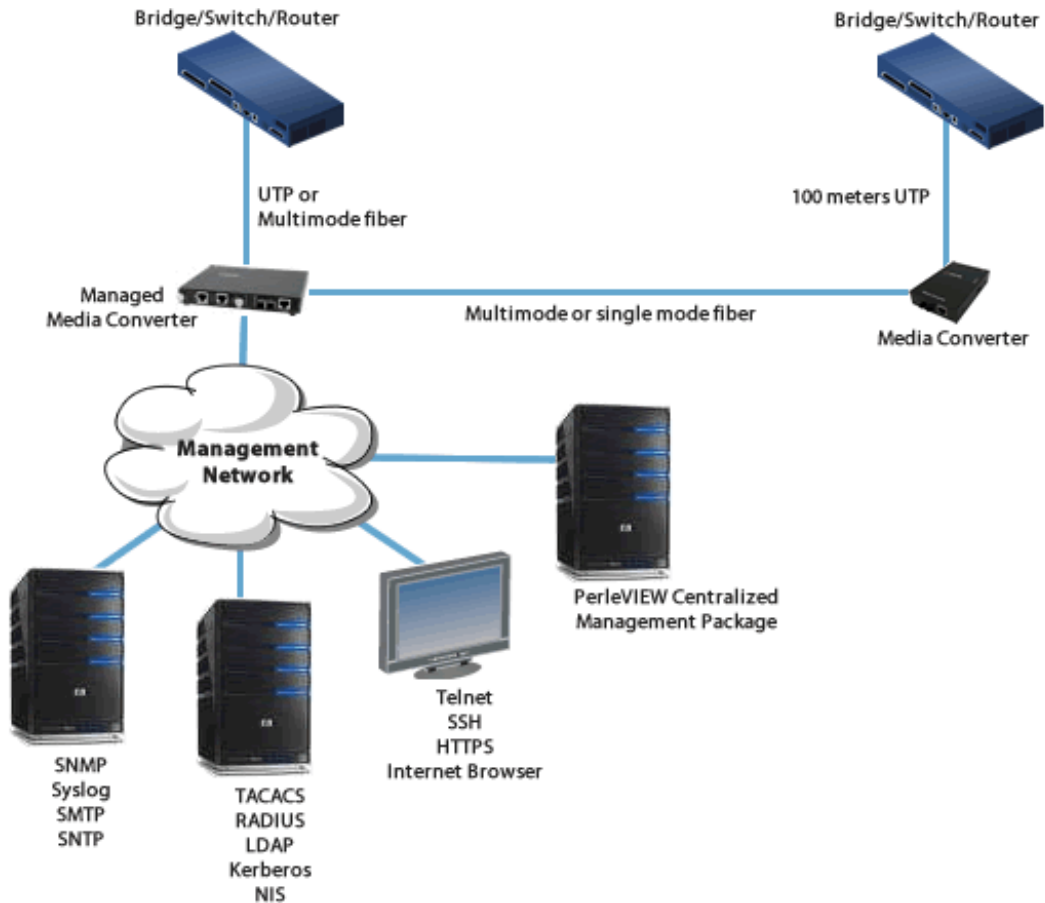

Fast Ethernet Multimode Switch to Multimode Switch

Extend the network distance between two Multimode Fiber Switches
Two Fiber to Fiber Media Converters can extend the distance between Fiber Switches across a fiber link up to 120km in length.

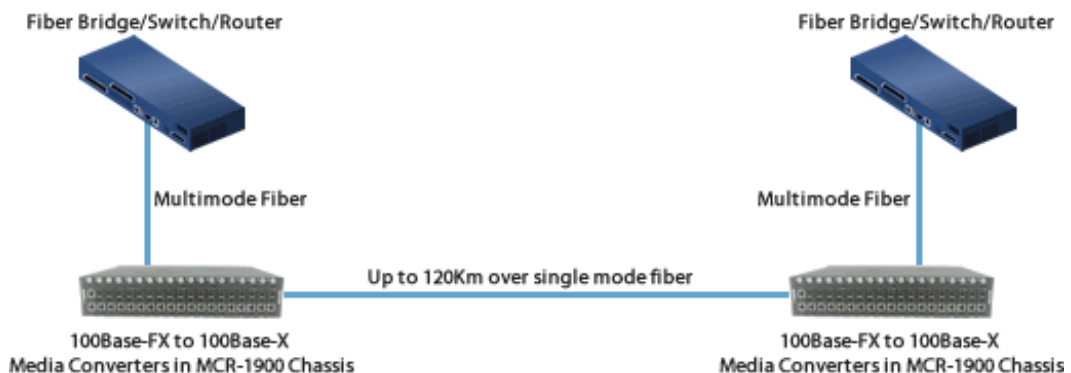

Single Mode / Single Fiber

Connect fiber ports over a single fiber strand (also referred to as “Bi-Directional” BiDi)

When Single Strand fiber is used, a pair of Single Fiber Media Converters is needed for the fiber to fiber conversion. Perle Single Fiber Media Converters are also referred to as “Up/Down” models. For example the CM-100MM-S1SC20U (“Up”) and CM-100MM-S1SC20D (“Down”), shown below, must be used in pairs. An “Up” must be matched with a “Down” peer to deal with transmit and receive frequencies separately.

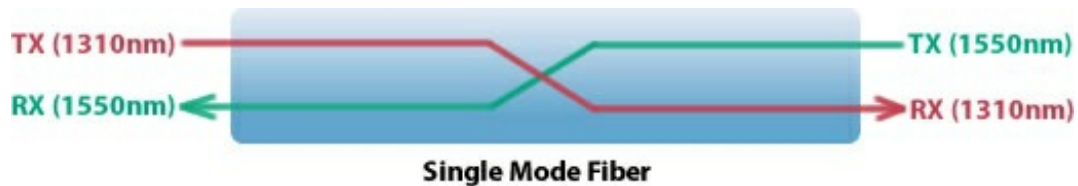

CM-100MM-S1SC20UCM-100MM-S1SC20D

The majority of installations for single mode fiber media converters are of the “dual connector” or “dual fiber” type where one fiber connection is used for transmit, the other for receive. These are physically “crossed” to match up the Transmit/Receive links.

However, to reduce costs, or where there are limits on available fiber, WDM technology may be utilized. WDM uses separate transmit and receive frequencies to communicate on a single fiber strand. WDM technology relies on the fact that optical fibers can carry many wavelengths of light simultaneously without interaction between each wavelength. Thus, a single fiber can carry many separate wavelength signals or channels simultaneously.

So remember, if Single Strand fiber is used, you will need an **Up** Media Converter on one side and a **Down** Media Converter on the other for fiber to fiber conversion.

Perle offers a wide variety of Single Fiber (**Up/Down**) Media Converters to connect 10BaseT, Fast Ethernet and Gigabit to single fiber. Whether you need Managed or Unmanaged, Standalone or Modular Chassis Based, 20km or 120km, Perle has the right model to meet your fiber conversion requirement.

Select a Model to obtain a Part Number - CM-100MM Fast Ethernet Fiber to Fiber Managed Media Converter Module

Model	Port	Connector	Type	Transmit (dBm)		Receive (dBm)		Power Budget (dBm)	Wavelength (nm)
				Min	Max	Min	Max		
CM-100MM-M2ST2	Port 1	Dual ST	100BASE-FX	-20.0	-12.0	-31.0	-14.0	11.0*	1310
	Port 2	Dual ST	100BASE-FX	-20.0	-12.0	-31.0	-14.0	11.0*	1310

	2		FX	20.0	12.0	31.0	14.0		
<u>CM-100MM-M2SC2</u>	Port 1	Dual SC	100BASE-FX	-20.0	-12.0	-31.0	-14.0	11.0*	1310
	Port 2	Dual SC	100BASE-FX	-20.0	-12.0	-31.0	-14.0	11.0*	1310
<u>CM-100MM-M2LC2</u>	Port 1	Dual LC	100BASE-FX	-20.0	-12.0	-30.0	-14.0	10.0*	1310
	Port 2	Dual LC	100BASE-FX	-20.0	-12.0	-30.0	-14.0	10.0*	1310
<u>CM-100MM-S2ST20</u>	Port 1	Dual ST	100BASE-FX	-20.0	-12.0	-31.0	-14.0	11.0*	1310
	Port 2	Dual ST	100BASE-LX	-18.0	-7.0	-32.0	-3.0	14.0	1310
<u>CM-100MM-S2SC20</u>	Port 1	Dual SC	100BASE-FX	-20.0	-12.0	-31.0	-14.0	11.0*	1310
	Port 2	Dual SC	100BASE-LX	-18.0	-7.0	-32.0	-3.0	14.0	1310
<u>CM-100MM-S2LC20</u>	Port 1	Dual LC	100BASE-FX	-20.0	-12.0	-30.0	-14.0	10.0*	1310
	Port 2	Dual LC	100BASE-LX	-15.0	0.0	-34.0	-5.0	19.0	1310
<u>CM-100MM-S2ST40</u>	Port 1	Dual ST	100BASE-FX	-20.0	-12.0	-31.0	-14.0	11.0*	1310
	Port 2	Dual ST	100BASE-EX	-5.0	0.0	-34.0	-3.0	29.0	1310
<u>CM-100MM-S2SC40</u>	Port 1	Dual SC	100BASE-FX	-20.0	-12.0	-31.0	-14.0	11.0*	1310
	Port 2	Dual SC	100BASE-EX	-5.0	0.0	-34.0	-3.0	29.0	1310
<u>CM-100MM-S2LC40</u>	Port 1	Dual LC	100BASE-FX	-20.0	-12.0	-30.0	-14.0	10.0*	1310
	Port 2	Dual LC	100BASE-EX	-5.0	0.0	-34.0	-3.0	29.0	1310
<u>CM-100MM-S2ST80</u>	Port 1	Dual ST	100BASE-FX	-20.0	-12.0	-31.0	-14.0	11.0*	1310
	Port 2	Dual ST	100BASE-ZX	-5.0	0.0	-34.0	-3.0	29.0	1550

<u>CM-100MM-S2SC80</u>	Port 1	Dual SC	100BASE-FX	-20.0	-12.0	-31.0	-14.0	11.0*	1310
	Port 2	Dual SC	100BASE-ZX	-5.0	0.0	-34.0	-3.0	29.0	1550
<u>CM-100MM-S2LC80</u>	Port 1	Dual LC	100BASE-FX	-20.0	-12.0	-30.0	-14.0	10.0*	1310
	Port 2	Dual LC	100BASE-ZX	-5.0	0.0	-34.0	-3.0	29.0	1550
<u>CM-100MM-S2ST120</u>	Port 1	Dual ST	100BASE-FX	-20.0	-12.0	-31.0	-14.0	11.0*	1310
	Port 2	Dual ST	100BASE-ZX	0.0	5.0	-35.0	-3.0	35.0	1550
<u>CM-100MM-S2SC120</u>	Port 1	Dual SC	100BASE-FX	-20.0	-12.0	-31.0	-14.0	11.0*	1310
	Port 2	Dual SC	100BASE-ZX	0.0	5.0	-35.0	-3.0	35.0	1550
<u>CM-100MM-S2LC120</u>	Port 1	Dual LC	100BASE-FX	-20.0	-12.0	-30.0	-14.0	10.0*	1310
	Port 2	Dual LC	100BASE-ZX	0.0	5.0	-34.0	-3.0	34.0	1550

Single Fiber Models (Recommended use in pairs)

Model	Port	Connector	Type	Transmit (dBm)		Receive (dBm)		Power Budget (dBm)	Wav (
				Min	Max	Min	Max		
<u>CM-100MM-S1ST20U</u>	Port 1	Dual ST	100BASE-FX	-20.0	-12.0	-31.0	-14.0	11.0*	1310
	Port 2	Single ST	100BASE-BX	-14.0	-8.0	-32.0	-3.0	18.0	1310
<u>CM-100MM-S1ST20D</u>	Port 1	Dual ST	100BASE-FX	-20.0	-12.0	-31.0	-14.0	11.0*	1310
	Port 2	Single ST	100BASE-BX	-14.0	-8.0	-32.0	-3.0	18.0	1550
<u>CM-100MM-S1SC20U</u>	Port 1	Dual SC	100BASE-FX	-20.0	-12.0	-31.0	-14.0	11.0*	1310
	Port 2	Single SC	100BASE-BX	-14.0	-8.0	-32.0	-3.0	18.0	1310

<u>CM-100MM-S1SC20D</u>	Port 1	Dual SC	100BASE-FX	-20.0	-12.0	-31.0	-14.0	11.0*	131C
	Port 2	Single SC	100BASE-BX	-14.0	-8.0	-32.0	-3.0	18.0	155C
<u>CM-100MM-S1SC40U</u>	Port 1	Dual SC	100BASE-FX	-20.0	-12.0	-31.0	-14.0	11.0*	131C
	Port 2	Single SC	100BASE-BX	-8.0	-3.0	-33.0	-3.0	25.0	131C
<u>CM-100MM-S1SC40D</u>	Port 1	Dual SC	100BASE-FX	-20.0	-12.0	-31.0	-14.0	11.0*	131C
	Port 2	Single SC	100BASE-BX	-8.0	-3.0	-33.0	-3.0	25.0	155C

The minimum fiber cable distance for all converters listed is 2 meters.

*Based on use with 62.5/125 micron multimode fiber.

