

S-1110HP-SFP-XT Hi-PoE Media Converters

 perle.com/products/media-converters/s-1110hp-sfp-xt-hi-poe-media-converters.shtml

IEEE 802.3bt Compliant PoE & Fiber Media Conversion

- 10/100/1000Base-T to 100/1000Base-X Fiber
- 1 or 2 empty slots for Cisco and other industry standard SFPs
- Supplies IEEE 802.3bt Hi-PoE PSE (up to 100W) power
- Compatible with IEEE 802.3af PoE and IEEE 802.3at PoE+ PoE devices
- Dual or Single 10/100/1000Base-T PoE ports
- Advanced features: PD Reset, Fiber redundancy, Smart Link Pass-Through, Fiber Fault Alert, Auto-MDIX and Loopback
- -40°F to +167°F (-40°C to +75°C) extended operating temperature



Perle S-1110HP-SFP-XT Fiber Media Converters transparently connect copper to fiber while providing up to 100 Watts of IEEE 802.3bt compliant Hi-PoE PSE power to standards-based compliant devices. Equipment found in traffic management, oil and gas pipelines, weather tracking, industrial and outdoor applications must function in temperatures that cannot be supported by a commercial based media converter. With an operating temperature -40°F to +167°F (-40°C to +75°C) this Hi-PoE Media Converter is ideal for use with industrial devices subjected to harsh environments and severe temperatures such as pan-tilt-zoom (PTZ) security cameras with heaters, 802.11ax/ac wireless access points, alarms, traffic controllers, sensors and tracking devices.

Perle Hi-PoE Media Converters are classified as Power Sourcing Equipment (PSE). While using standard UTP cables that carry Ethernet data, Perle Hi-PoE media converters provide power to Powered Devices (PDs) that support the IEEE 802.3bt PoE standard (up to 100W of power) or pre-standard solutions including UPoE, 4PPoE, PoE++, UltraPoE, 4 Pair PoE, etc. As this standard is fully backwards compatible with the existing IEEE 802.3af PoE and IEEE 802.3at PoE+ standards, all of those PD's are also supported. The S-1110HP-SFP Fiber Media Converter features single or dual 10/100/1000Base-T RJ45 ports to power one or two PD's per converter [Learn more about PoE](#)

And, with one or two empty transceiver ports on the S-1110HP-SFP Fiber Media Converter, flexible network configurations requirements can be met using a variety of transceivers supplied by Perle [transceivers supplied by Perle](#), [Cisco](#), or other manufacturers of MSA compliant SFPs.

- extend the life of non-fiber based equipment by enabling data transmission from 10/100/1000Base-T devices over 100/1000Base-X fiber
- extend the distance of an existing network by linking CAT5/6/7 cabling to multimode or single mode fiber
- protect Ethernet data from EMI noise and interference by inter-connecting your copper-Ethernet devices over fiber.

Network Administrators can "see-everything" with Perle's advanced features such as Auto-Negotiation, Auto-MDIX, Link Pass-Through, Fiber Fault Alert, and Loopback. This allows for more efficient troubleshooting and less on-site maintenance. These cost and time saving features, along

with a lifetime warranty and free worldwide technical support, make Perle S-1110HP-SFP-XT PoE Media Converters the smart choice for IT professionals.

S-1110HP-SFP-XT Hi-PoE Media Converter Features

Power Over Ethernet (PSE) Fully Compliant with IEEE 802.3bt Type 3 and 4 PSE

Performs the Power Sourcing Equipment (PSE) function on 1 or 2 UTP ports for IEEE 802.3bt compliant devices.

All models support Type 1 (PoE), Type 2 (PoE+), Type 3 (Hi-PoE) and Type 4 (Hi-PoE) PD gear

Advanced Power Management

- Enable/Disable PSE power by UTP port
- Single or Dual PD signature detection
- Over-Current Protection
- PD power classification detection (Class 0)

PD Power Reset Ideal for remotely resetting equipment, this configurable function performs a momentary power reset to the attached Powered Device (PD). When enabled, the media converter will, upon loss of fiber RX, turn off PSE output power supplied to the PD device for 2 seconds then turn the power back on and leave it on until such time that another fiber RX link is lost (after it was re-established). When disabled, a loss of fiber RX has no effect on PSE power to the PD device(s).

Powered Device Support Type: 1, 2, 3, and 4 PDs

Class: 1, 2, 3, 4, 5, 6, 7, 8 PDs

Supports both Single-Signature and Dual-Signature PD connections

Multiport Configurations

- 2 port: 1x 10/100/1000Base-T and 1x SFP fiber slot
- 3 port: 1x 10/100/1000Base-T and 2x SFP fiber slots
- 4 port: 2x 10/100/1000Base-T and 2x SFP fiber slots

Fiber Redundancy When enabled on dual fiber models, the media converter treats Fiber 1 as the primary and if the link fails, the fiber link is switched over to fiber 2 within 50ms.

Redundant Primary Fiber If the “Fiber Redundancy” feature is also enabled, the primary fiber 1 link is continuously monitored and if is restored for at least 6 seconds, the link will be switched back from the secondary fiber 2 port to the primary fiber 1 port.

Power Strain Relief strap Included with all models, a strain relief strap is provided to ensure a solid and secure power connection to the media converter. Ideal for areas that may be exposed to vibration.

SFP Speed Sensing	Automatically detects whether a <u>Gigabit or Fast Ethernet fiber SFP</u> has been inserted and adjusts accordingly.
Auto-Negotiation (802.3u)	<p>The media converter supports auto negotiation. The 1000Base-X fiber interface negotiates according to 802.3 clause 37. The 10/100/1000Base-T negotiates according to 802.3 clause 28 and 40. The 1000Base-X will link up with its partner after the highest common denominator (HCD) is reached and the copper has linked up with its partner. The 1000Base-X will continue to cycle through negotiation transmitting a remote fault of offline (provided this is enabled through the switch setting) until the copper is linked up and the HCDs match.</p> <p>The media converter supports auto-negotiation of full duplex, half duplex, remote fault, full duplex pause, asymmetric pause and Auto MDI-X.</p>
Auto-MDIX	<p>Auto-MDIX (automatic medium-dependant interface crossover) detects the signaling on the copper Ethernet interface to determine the type of cable connected (straight-through or crossover) and automatically configures the connection when enabled. The media converter can also correct for wires swapped within a pair.</p> <p>The media converter will adjust for up to 120ns of delay skew between the 1000Base-T pairs.</p>
Smart <u>Link Pass-Through</u>	When the Link Mode switch is placed into Smart Link Pass-Through mode, the copper Ethernet port will reflect the state of the 1000Base-X media converter port. This feature can be used whether fiber auto-negotiation is enabled or disabled.
Fiber Fault Alert	With Fiber Fault Alert the state of the 1000Base-X receiver is passed to the 1000Base-X transmitter. This provides fault notification to the partner device attached to the 1000Base-X interface of the media converter. If the 1000Base-X transmitter is off as a result of this fault it will be turned on periodically to allow the condition to clear should the partner device on the 1000Base-X be using a similar technique. This eliminates the possibility of lockouts that occur with some media converters. Applies only when fiber auto-negotiation is disabled.
Pause (IEEE 802.3xy)	<p>Pause signaling is an IEEE feature that temporarily suspends data transmission between two devices in the event that one of the devices becomes overwhelmed. The media converter supports pause negotiation on the 10/100/1000Base-T connection and 1000Base-X fiber connection.</p> <ul style="list-style-type: none"> • With Autoneg on the device will advertise sym and asymmetric pause • With Autoneg off – Pause receive and send will be disabled

Duplex	Full and half duplex operation supported.
Jumbo Packets	Transparent to jumbo packets up to 10KB.
VLAN	Transparent to VLAN tagged packets.
Remote Loopback	Capable of performing a loopback on the 1000Base-X fiber interface.

Not what you are looking for? View all Perle [Media Converters](#).
Need help? [Contact Perle](#).

Power

Input Supply Voltage	52 - 57 vDC
Power Consumption	1 x 10/100/1000Base-T port models: 4 watts 2 x 10/100/1000Base-T port models: 4.7 watts Note: for the HP PoE SFP models the numbers above don't include the SFP power consumptions
Power Over Ethernet (PSE)	up to 100 watts per port
Power Connector	4 pin DIN connector



Indicators

Power (PWR)	This green LED is turned on when power is applied to the media converter. Otherwise it is off. The LED will blink slowly when either fiber port is in Loopback test mode. The LED will blink quickly if there is a hardware failure where the reason code can be identified through a combination of FDF, LKF, FDC and PSE indicator LEDs
Fiber link on / Receive activity (LKF 1/2)	This green LED is operational only when power is applied. The LED will blink along with transmit/receive data on the fiber port If a loss of link on the copper port results in a Link Passthrough condition to the fiber port, this LED will blink at a rate of once every 2 seconds until the condition is cleared.

Copper link on / Receive activity (LKC 1/2)	<p>This green LED is operational only when power is applied. The LED will blink along with transmit/receive data on the 10/100/1000 UTP port</p> <p>If a loss of link on the copper port results in a Link Passthrough condition to the fiber port, this LED will blink at a rate of once every 2 seconds until the condition is cleared.</p>
Fiber Duplex (FDF 1/2)	<p>This green LED is operational only when power is applied. The LED is on when the 10/100/1000Base-X link is operational in full duplex mode. The LED is off when in half duplex. If the Auto-Neg switch is turned off, this LED will always be on</p>
Copper Duplex (FDC 1/2)	<p>This green LED is operational only when power is applied. The LED is on when the 10/100/1000Base-T link is operational in full duplex mode. The LED is off when in half duplex</p>
100/1000	<p>This multi-color LED is operational only when power is applied. The LED is green when the speed of the copper ethernet port is running at 1000 Mbps. The LED is yellow when the speed of the copper Ethernet port is running at 100 Mbps. The LED is off when in 10 Mbps.</p>
PSE Status (PSE 1/2)	<p>This LED will signify the status of the PSE function. Using multi-color and blinking the unit will show the following status for the PSE;</p> <p>GREEN — Solid: The PSE has successfully detected a compliant PD and is applying power over the UTP (for legacy pin out simply show active power when applied)</p> <p>YELLOW — Solid: The PSE is not active. This means the PSE has been configured to provide power, but the PD is :</p> <ul style="list-style-type: none"> • Not connected • Has not detected a compliant PD and is not applying power • PSE has turned off power for Reset function <p>OFF — PSE function switch disabled</p> <p>RED — Blinking: Error Conditions</p> <ul style="list-style-type: none"> • Capacitance too High — 1 blink • Resistance too Low or short circuit — 2 blinks • Resistance too high or open circuit — 3 blinks

Switches - accessible through a side opening in the chassis



Auto-Negotiation (802.3u) *Enabled (Default)* - The media converter uses 802.3u Auto-negotiation on the 10/100/1000Base-T interface. It is set to advertise full duplex, half duplex, pause and remote fault capabilities.
Disabled - The media converter sets the port according to the position of the speed and duplex switches.

Link Mode Link Mode provides a transparency to the state of the copper link allowing for simplified trouble shooting from the devices connected to the media converter.

Normal (Default — Up)

With Fiber Auto Negotiation enabled when the copper link goes down the 1000Base-X link is brought down. The 1000Base-X link will advertise Remote Fault (Link Fault).

With Fiber Auto Negotiation disabled the state of the copper link has no effect on the 1000Base-X link.

Smart Link Pass Through (Down)

With Fiber Auto Negotiation enabled the behavior is as follows. When the copper link goes down the 1000Base-X link is brought down. The 1000Base-X link will advertise Remote Fault (Link Fault). When Remote Fault (Link Fault) is received on the 1000Base-X interface the copper transmitter will be turned off. When the copper receiver is off the 1000Base-X transmitter will be turned off. When the 1000Base-X receiver goes off the copper transmitter will be turned off.

With Fiber Auto-Negotiation disabled the behavior is as follows. When the copper receiver is off the 1000Base-X transmitter will be turned off. When the 1000Base-X receiver goes off the copper transmitter will be turned off.

Fiber Fault Alert The Fiber Fault Alert switch has meaning when Auto-Negotiation is disabled

Enabled (Default - Up)

When the 1000Base-X receiver is off the 1000Base-X transmitter is turned off. Periodically the 1000Base-X receiver will be turned on for a short period to allow the condition to clear if the 1000Base-X link partner is using a similar feature.

Disabled (Down)

Loopback The media converter can perform a loopback on the 1000Base-X fiber interface.

Disabled (Default - Up)

Enabled - The 1000Base-X receiver is looped to the 1000Base-X transmitter. The copper transmitter is taken off the interface.

X transmitter. The copper transmitter is taken off the interface.

Speed Copper	100 (Default) 10
--------------	---------------------

Duplex Copper	Full (Default) Half
---------------	------------------------

Fiber Negotiation	<p><i>Up:</i> The Media Converter will negotiate Ethernet parameters on the fiber connection. This will ensure that the most optimal connection parameters will be in effect. If connecting to another Perle Media Converter, this parameter should be set to Auto. The Media Converter Module will advertise 1000Mbps, Full and Half Duplex, no Pause.</p> <p><i>Down:</i> The Media Converter Module's fiber will be fixed to 1000Mbps, Full Duplex.</p>
-------------------	--

Auto-MDIX (Internal Strap)	<p>If Auto-Negotiation (802.3u) is enabled, the media converter determines the current cable pinout to use on the copper interface. If Auto-Negotiation (802.3u) is disabled the Media converter will use the RX Energy method on the copper interface to set the port MDI or MDIX whichever is appropriate.</p> <p>Enabled (Default) - Either a straight-through or crossover type cable can be used to connect the media converter to the device on the other end of the cable.</p> <p>Disabled - If the partner device on the other end of the cable does not have the Auto-MDIX feature a specific cable, either a straight-through or crossover will be required to ensure that the media converter's transmitter and the partner devices transmitter are connected to the others receiver. The Media converter's 100Base-TX port is configured as MDI-X with this switch setting.</p>
-------------------------------	---

PSE Power	<p>Settable for each UTP port available.</p> <p>When enabled (UP), the media converter will perform a Power Sourcing Equipment (PSE) function as per IEEE802.3bt standard.</p> <p>Default is "enabled"</p>
-----------	--

PD Power Reset	<p>This is a technique to perform a power reset on a PD device(s) attached.</p> <p>When enabled (down), the media converter will upon loss of link on any fiber port, turn off PSE output power to the PD device(s) for 2 seconds then turn the power back on. The power remains on until any fiber link transitions from up to down again.</p> <p>With Passthrough enabled (Link Mode enabled and Fiber Auto-Negotiation enabled) a loss of link on the fiber resulting from a</p>
----------------	---

negotiation enabled), a loss of link on the fiber resulting from a loss of link on the copper, a PD Power Reset will still occur.

When PD Power Reset disabled, loss of fiber link has no effect on PSE power to the PD device(s).

PoE power vs Ethernet CAT	CAT3 and above for PoE power up to 15.4 watts
	CAT5 and above for PoE power between 15.4 watts and up to 30 watts
	CAT6 and above for PoE power between 30 watts and up to 100 watts
	Note: always choose the highest Ethernet CAT category between desired speed and PoE power

Connectors

10/100/1000Base-T	RJ45 connector
	2 pair CAT5, EIA/TIA 568A/B or better cable for 10/100.
	4 pair CAT5 UTP cable for Gigabit.
	Note: always choose the highest Ethernet CAT category between desired speed and PoE power

Magnetic Isolation	1.5kv
--------------------	-------

Small Form Factor Pluggable (SFP) slot	SFP slot models: Empty slot for 1000Base-X or 100Base-XSFP modules supplied by Perle , Cisco or other manufacturers of MSA compliant SFPs.
	Hot insertion and removable (hot swappable).

Filtering

Filtering	1024 MAC Addresses
-----------	--------------------

Frame Specifications

Buffer	1000 Kbits frame buffer memory
Size	Maximum frame size of 10,240 bytes -- Gigabit Maximum frame size of 2048 bytes -- Fast Ethernet

Environmental Specifications

Operating Temperature	-40 C to 75 C (-40 F to 167 F)
Storage Temperature	-40 C to 85 C (-40 F to 185 F)

Temperature

Operating Humidity	5% to 90% non-condensing
Storage Humidity	5% to 95% non-condensing
Operating Altitude	Up to 3,048 meters (10,000 feet)
Heat Output (BTU/HR)	1 x 10/100/1000Base-T port models: 13.65 BTU/hr 2 x 10/100/1000Base-T port models: 16 BTU/hr
MTBF (Hours)*	324134
Chassis	Metal with an IP20 ingress protection rating

Mounting

Din Rail Kit	Optional
Rack Mount Kit	Optional

Product Weight and Dimensions

Weight	0.4 Kg, 1.0 lbs (no power adaptor)
Dimensions	150 x 95 x 26 mm, 5.9 x 3.7 x 1.0 inches

Packaging

Shipping Weight	0.56 kg, 1.2 lbs
Shipping Dimensions	300 x 200 x 70 mm, 11.81 x 7.87 x 2.75 inches

Regulatory Approvals

Emissions	FCC Part 15 Class A, EN55022 Class A CISPR 22 Class A CISPR 32:2012/EN 55032:2012 (Class A) CISPR 24:2010/EN 55024:2010 EN61000-3-2
Immunity	EN55024
Electrical Safety	IEC 62368-1(ed 2) EN 62368-1:2014 CE
Environmental	<u>Reach, RoHS and WEEE Compliant</u>
Other	FCCN: 5A991

HTSUS Number: 8517.62.0050

Perle Limited Lifetime Warranty

*Calculation model based on MIL-HDBK-217-FN2 @ 30 °C

Gigabit Fiber to IP Cameras

Connect 10/100/1000 IP Cameras to Gigabit Backbone

Extend the reach to IP cameras using fiber media converters. Security cameras are typically installed in remote locations throughout a facility. For cameras that are in the ceiling or other inaccessible areas like rooftops, light poles, along fences, pipelines and transit routes, the cost of bringing electrical power to each camera is eliminated by powering the equipment through the UTP cable using a PoE media converter. Cameras with features like Pan-Tilt-Zoom (PTZ), heaters, de-icers, or blowers generally require higher power (30-100 Watts), making the Perle S-1110HP PoE Media Converters the ideal solution.

Fiber is run from an existing data closet to an area with access to power. The Hi-PoE Media Converter can be powered by 57vDC or standard 100 to 240 AC power. The media converter is attached to the power supply and the fiber cable. Copper (UTP or STP cable) Ethernet can be extended another 100 meters to the IP camera. The Hi-PoE Media Converter is converting the data from fiber to copper, adding power and transmitting it to the security camera.

To simplify cabling, multiport PoE media converters enable chaining, with a fiber uplink port and a fiber downlink port, of the fiber between media converters (also known as a bus architecture).

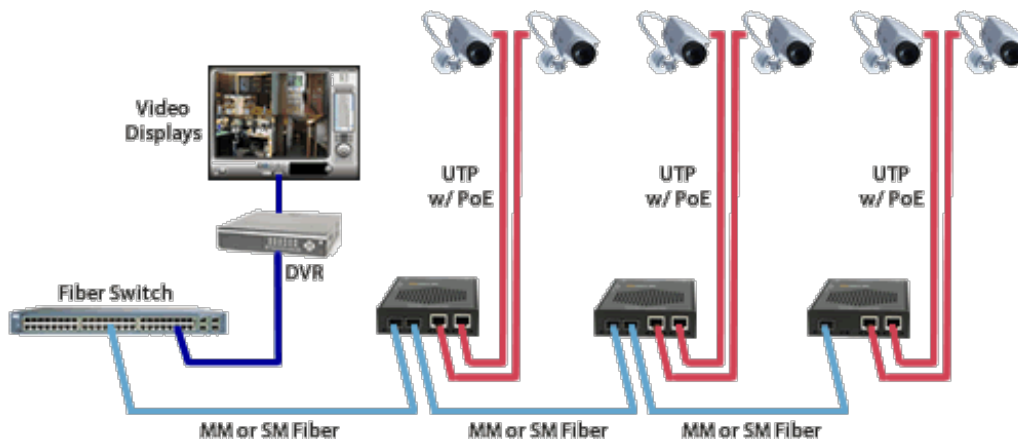

A second option is to have redundant fiber links for installations requiring fiber facility protection. There is an active fiber port and a protection fiber port that can support a fiber failure switchover of less than 50 milliseconds. The Hi-PoE media converter supplies power to the camera, and has power protection from an Uninterruptible Power Supply (UPS) battery back-up. In the event of a fiber cut and a loss of power, the camera continues to send data on the protection link.



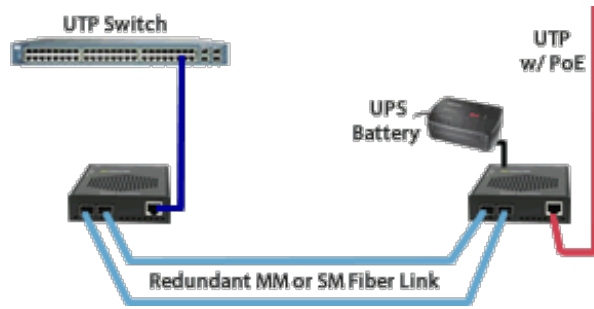

Gigabit Fiber to Wireless Access Points

Connect 10/100/1000 Wireless Access Points to Gigabit Backbone

Extend the reach to wireless access points (AP) using fiber media converters. When a company deploys a wireless network in their office or large warehouse, APs need to be set up throughout the facility to ensure complete coverage for reliability. The network manager will likely need to extend further than the 100 meters allowed by copper cable to reach many of the APs.

For wireless access points that require 30-100 Watts, such as those meeting the 802.11ax standard, 802.11ac standard or containing dual radios, the Perle S-1110HP PoE Media Converter is the ideal solution.

Fiber is run from an existing data closet to an area with access to power. The Hi-PoE Media Converter can be powered by 57vDC or standard 100 to 240 AC power. The media converter is attached to the power supply and the fiber cable. Copper (UTP or STP cable) Ethernet can be extended another 100 meters to the Wireless Access Point. The Hi-PoE Media Converter is converting the data from fiber to copper, adding power and transmitting it to the WAP.

To simplify cabling, multiport PoE media converters enable chaining, with a fiber uplink port and a fiber downlink port, of the fiber between media converters (also known as a bus architecture).

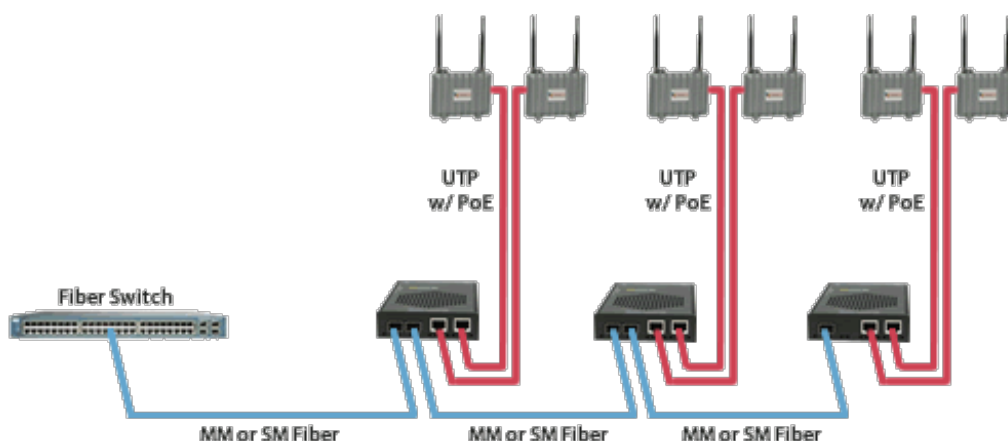

A second option is to have redundant fiber links for installations requiring fiber facility protection. There is an active fiber port and a protection fiber port that can support a fiber failure switchover of less than 50 milliseconds. The PoE+ media converter supplies power to the camera, and has power protection from an Uninterruptible Power Supply (UPS) battery back-up. In the event of a fiber cut and a loss of power, the camera continues to send data on the protection link.

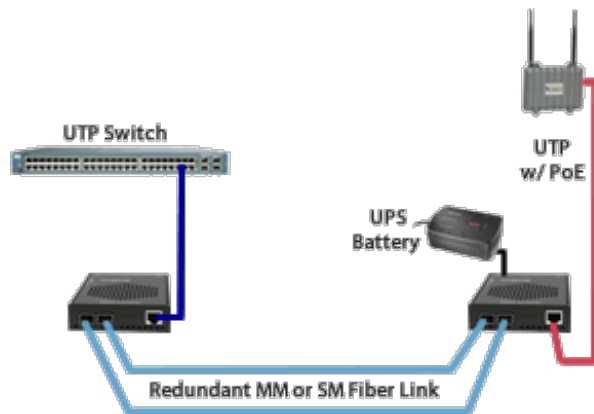

Gigabit Fiber to the Desktop / VoIP (Voice over IP) Phones

Connect 10/100/1000 workstations and VoIP Phones to a Gigabit Backbone

Extend the reach to your workstation and VoIP phones using fiber media converters. For VoIP phones that require 30-100 Watts power, such as those containing dual radios, the Perle S-1110HP PoE Media Converter is the ideal solution.

Fiber is run from an existing data closet to an area with access to power. The Hi-PoE Media Converter can be powered by 57vDC or standard 100 to 240 AC power. The media converter is attached to the power supply and the fiber cable. Copper (UTP or STP cable) Ethernet can be extended another 100 meters to the IP Phone. The Hi-PoE Media Converter is converting the data from fiber to copper, adding power and transmitting it to the IP Phone.

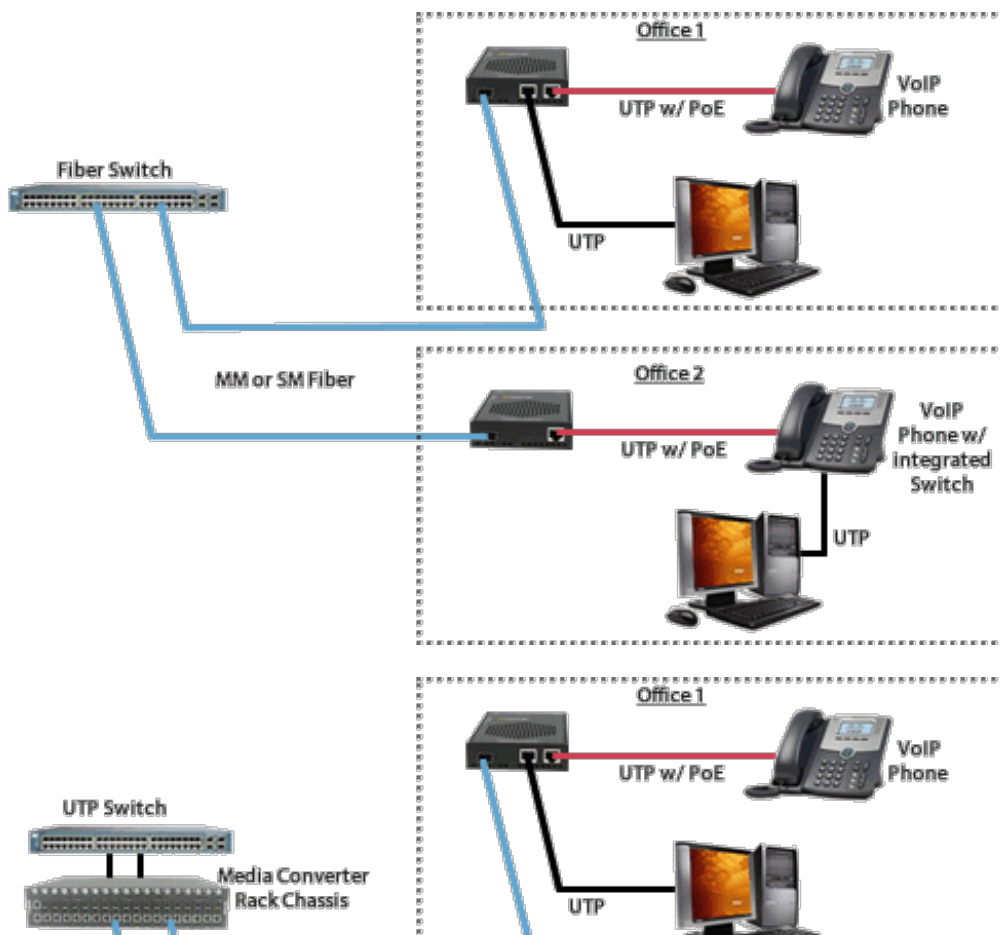

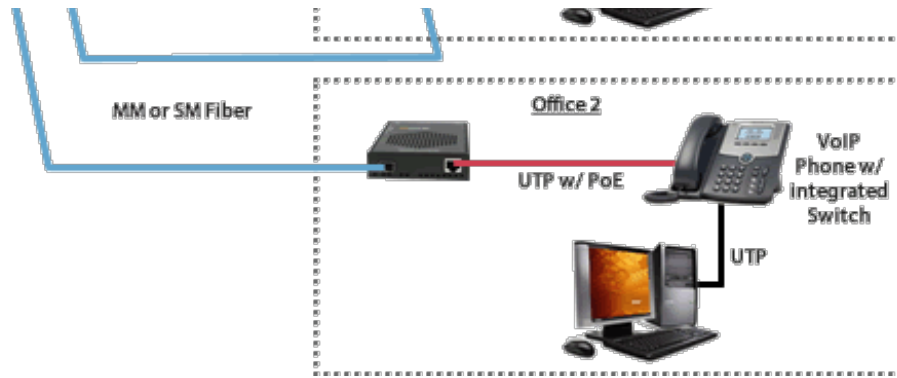

Redundant Dual-Fiber Uplink

Assured Fiber Uplink Connectivity for your critical equipment

When extending the reach of your critical Ethernet equipment using fiber media converters, a dual fiber port media converter with Fiber Redundancy capability provides a fast switch-over of link traffic from one fiber connection to the other converters.

Two modes of operation are possible.;

1. **Redundant Fiber** : When the primary link fails, the media converter redirects traffic to the other fiber port within 50ms.

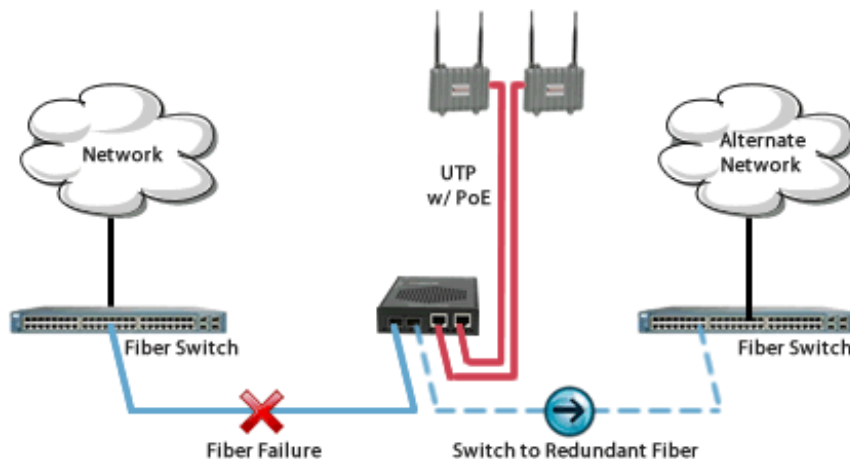

2. **Redundant Primary** : When the primary link fails, the media converter redirects traffic to the secondary fiber port within 50ms. Upon restoration of the primary fiber link, traffic is automatically redirected back to the primary fiber.

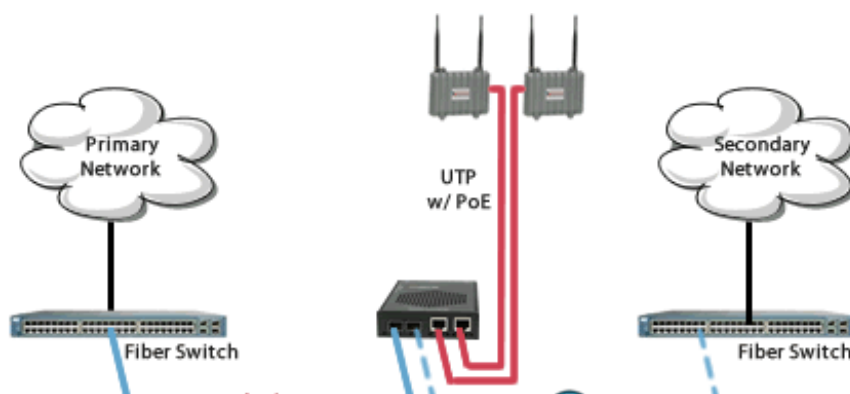

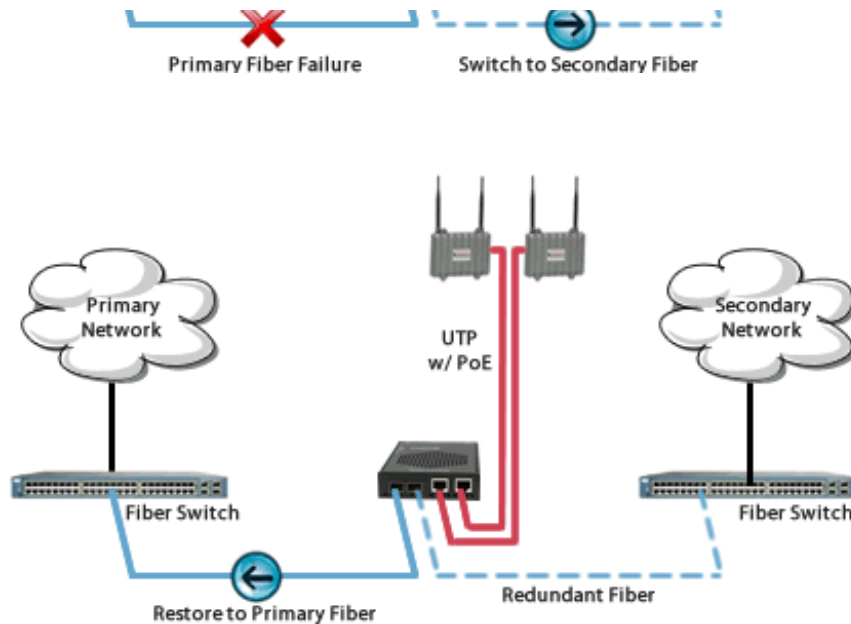

Single Mode / Single Fiber

Connect copper ports over a single fiber strand (also referred to as “Bi-Directional” BiDi)

When Single Strand fiber is used, a pair of Single Fiber Media Converters is needed for the copper to fiber conversion. Perle Single Fiber Media Converters are also referred to as “Up/Down” models. For example the S-1110HP-SC05U (“Up”) and S-1110HP-SC05D (“Down”), shown below, must be used in pairs. An **U**p must be matched with a **D**own peer to deal with transmit and receive frequencies separately.

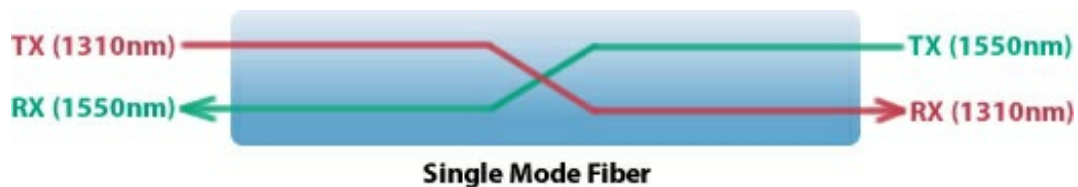

S-1110HP-SC05US-1110HP-SC05D

The majority of installations for single mode fiber media converters are of the “dual connector” or “dual fiber” type where one fiber connection is used for transmit, the other for receive. These are physically “crossed” to match up the Transmit/Receive links.

However, to reduce costs, or where there are limits on available fiber, WDM technology may be utilized. WDM uses separate transmit and receive frequencies to communicate on a single fiber strand. WDM technology relies on the fact that optical fibers can carry many wavelengths of light simultaneously without interaction between each wavelength. Thus, a single fiber can carry many separate wavelength signals or channels simultaneously.

So remember, if Single Strand fiber is used, you will need an **Up** Media Converter on one side and a **Down** Media Converter on the other for copper to fiber conversion.

